



Cierres
eléctricos

*Electric door
openers*





Tecnología
Seguridad
Experiencia
Fabricación
*Technology
Security
Experience
Production*

NADAL BADAL, S.A.



➤ NADAL BADAL, S.A.

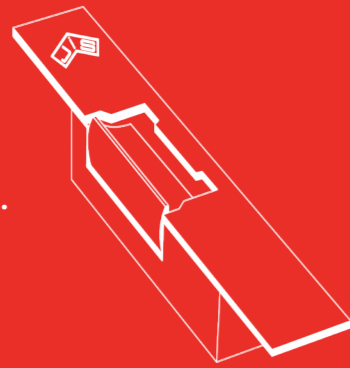

EXPERIENCIA

90 años fabricando cerraduras avalan la calidad de nuestros productos, que se han ido adaptando al paso del tiempo. Comercializados con la marca JIS, cubrimos todas las necesidades del mercado en más de 65 países.

TECNOLOGÍA

Atentos a los avances tecnológicos y gracias al trabajo de nuestro departamento de I+D, la evolución de los productos ha sido extraordinaria. Esto es lo que nos permite ofrecer una gama de cerraduras eléctricas con los sistemas más avanzados en cuanto al accionamiento y la seguridad.

SEGURIDAD

Las cerraduras siempre han sido un símbolo de seguridad y, por tanto, nuestros productos se fabrican para cumplir este objetivo primordial. Cuando los productos salen de nuestra fábrica, garantizamos la seguridad, un fácil accionamiento y una larga duración de los mismos.

EXPERIENCE

90 years in lock manufacturing guarantee the quality of our products, which have been evolving over the years. Under the brand name JIS, we meet market demands in over 65 countries.

TECHNOLOGY

Development of our products has been extraordinary, thanks the technological advances and the efforts of our R&D department. They have enabled us to produce a range of electric door openers, offering the most advanced mechanisms and highest levels of security.

SECURITY

Locks have always been a symbol of security and our products are manufactured to meet this primary objective. Security, ease of use and long life are guaranteed when our products leave the factory.

➤ ÍNDICE INDEX

➤ Cierres Eléctricos / Electric door opener

Conceptos prácticos / Practical concepts	8
Serie / Series 800 Básico / Basic	12
Serie / Series 1700 Simétrico / Symmetric	14
Serie / Series 1700 Micro / Monitored	16
Serie / Series 1700 Inverso / Fail Safe	17
Serie / Series 1700 Silencioso / Silent	18
Serie / Series 1700 Zumbador / Buzzer	19
Serie / Series 1400 Estrecho / Narrow	20
Serie / Series 1400 R Radial	22
Serie / Series 1400 RT Tobogán / Slide	24
Serie / Series 1480 RF Resistente al fuego / Fire resistant	26
Serie / Series 1500 Reforzado / Reinforced	28
Serie / Series 1580 RF Resistente al fuego / Fire resistant	30
Serie / Series Sobreponer / Rim	31
Serie / Series 1600 Antipanic	34
Serie / Series 1700 Antipanic	36
Serie / Series 1200 Vidrio / Glass	38
Serie / Series 1200 Tipo americano / Ansi style	39
Frontales / Front plates	40

➤ Twin locks / twin lock

Twin lock	46
-----------	----

➤ Cerraduras eléctricas / Electric locks

Cerraduras eléctricas / Electric locks	52
Electropistón / Electric dropbolt	54

➤ Sistemas de apertura / Opening systems

Teclado numérico / Keypad	58
Huella dactilar / Fingerprint	59
Control remoto / Remote control	60
Lector tarjeta / Car reader	61

➤ Electromagnéticos / Electromagnetics

Electromagnéticos / Electromagnetics	64
Accesorios instalación / Instalation brackets	68

➤ Accesorios / Accessories

Accesorios / Accessories	72
Ref. cerraduras eléctricas / Ref. electric door openers	76



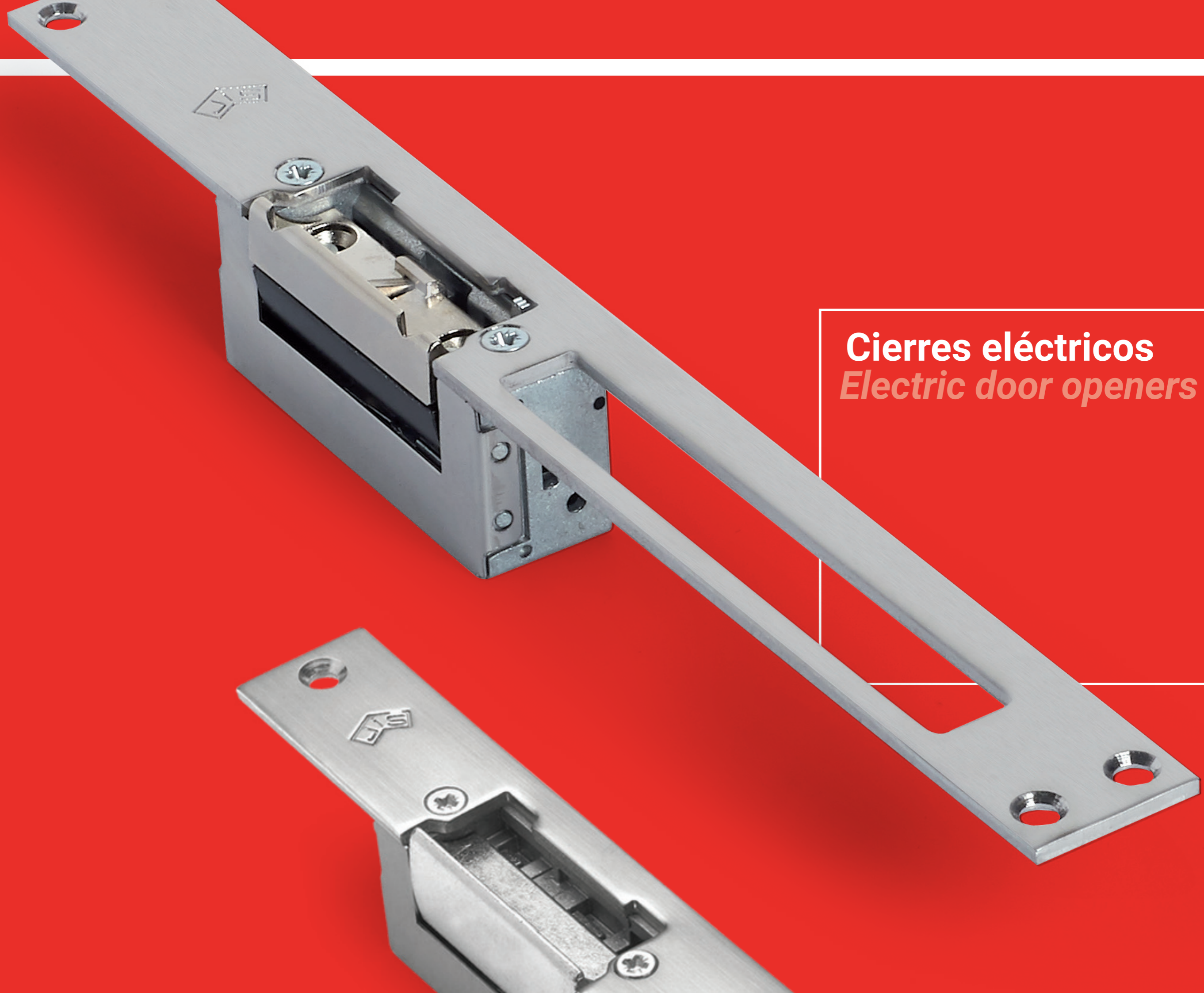

Cierres eléctricos
Electric door openers

COMPONENTES DE UN CIERRE ELÉCTRICO ELECTRIC DOOR OPENER PARTS

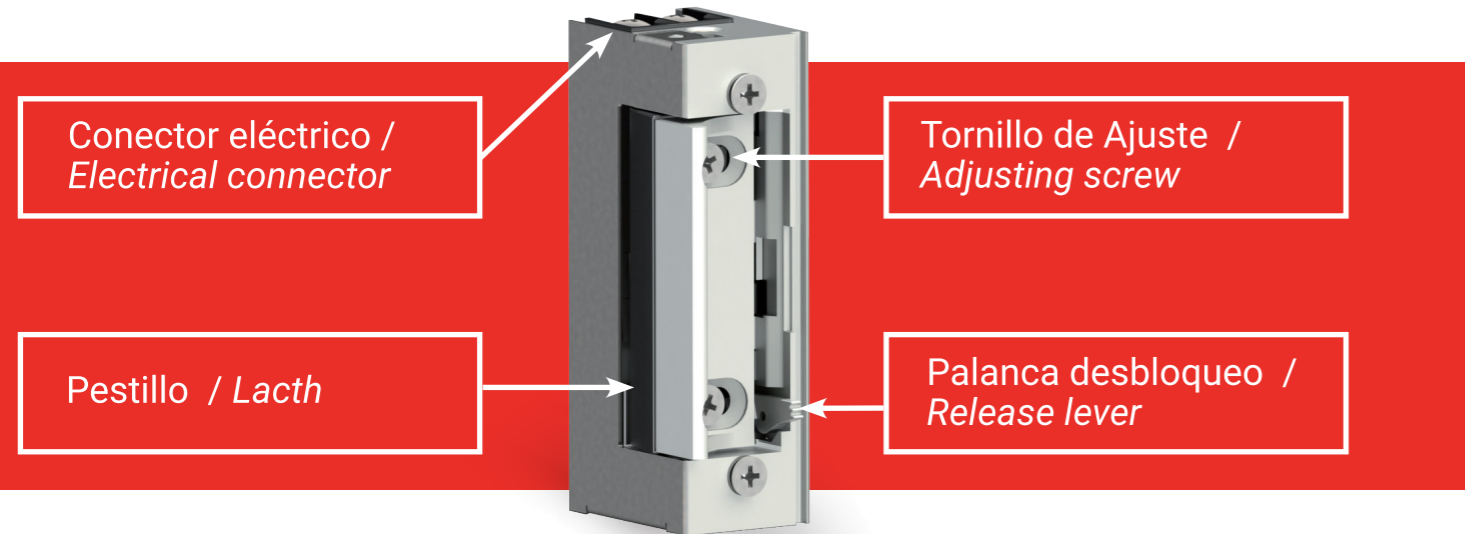

CONCEPTOS PRACTICOS PRACTICAL CONCEPTS



CIERRE ELÉCTRICO / ELECTRIC DOOR OPENER

Un cierre eléctrico reemplaza al cerradero instalado en el marco de una puerta, sea éste de aluminio, madera, acero, pvc... Permite la apertura de la puerta mediante un impulso eléctrico emitido por un pulsador, un sistema de apertura, un videoportero, etc...

An electric door opener replaces the strike installed in the frame of a door, be it aluminium, wood, steel, pvc ... It allows the door to be opened by an electrical impulse coming from a button, an opening system, a video door entry, etc

TIPO DE CORRIENTE / CURRENT TYPE

Alterna AC
Es el tipo de corriente más común. Los cierres eléctricos han de ser conectados mediante un transformador. Los cierres eléctricos conectados a corriente alterna emiten un zumbido característico.

Continua DC
Utilizada en sistemas que han de funcionar permanentemente conectados a placas electrónicas. Se han de conectar mediante una fuente de alimentación. No emiten el zumbido característico y tienen bajo consumo. En contrapartida, tienen poca capacidad de apertura con precarga.

Polaridad
El cierre eléctrico no guarda polaridad, salvo indicado expresamente.

Alternating current AC
It is the most common type of current. The electric strikes must be connected by a transformer. Electric strikes connected to alternating current make a characteristic buzz.

Continuous current DC
Used in general in those systems that have to work continuously or connected to electronic board. Must be connected to a power supply. They do not make the characteristic buzz and are low consumption. On the other hand, they have little opening capacity with preload.

Polarity
The electrical strike does not keep polarity, others than indicated.

ESTÁNDAR - INVERSO / FAIL SECURE- FAIL SAFE

Normal - Inverso
El cierre eléctrico en su versión normal, (NC) permanente cerrado sin impulso eléctrico. Al contrario, la versión inversa, (NO) permanece cerrada mientras recibe un impulso eléctrico.

Fail Secure - Fail Safe
The electric door opener in its fail secure version (NC) (or power to unlock), remains closed without an electrical impulse. Instead, the fail-safe (NO) version (or power to lock) remains closed while receiving an electrical impulse.

PESTITLO REGULABLE / ADJUSTABLE LATCH

El pestillo regulable permite el desplazamiento lateral, para un mejor ajuste del cierre eléctrico con el picaporte de la cerradura.

The adjustable latch allows lateral movement, for a better adjustment of the electric door opener with the latch of the lock.

PALANCA DE DESBLOQUEO / RELEASE LEVER

El cierre eléctrico puede ser desbloqueado mediante una palanca mecánica. Útil en los casos de fallo del sistema de alimentación o para permitir el paso continuo.

The electric door opener can be unlocked using a mechanical lever. Useful in cases of power system failure or to allow continuous passage.

MEMORIA (AUTOMÁTICO) / MEMORY (AUTOMATIC)

El cierre eléctrico se desbloquea al recibir el impulso eléctrico. Se mantiene desbloqueado hasta que la puerta se abre.

The electric door opener is unlocked when receiving the electrical impulse. Remains unlocked until the door opens.

Tipo de automatismos / Automatism types

Externa/External Pin (terminación de la referencia 30/40) / Pin (30/40 reference ending)

Sistema tradicional y simple.

Traditional system and simple.

El picaporte de la cerradura debe presionar el pin. Se debe hacer una instalación que asegure la presión sobre el mecanismo para que este actúe correctamente.

The latch of the lock must press the pin. The installation must be made to ensure the pressure on the mechanism so that it works correctly.

Interna (terminación de la referencia 33/43) / Internal (33/43 reference ending)

Facilidad de ajuste. El automatismo siempre funciona.

Easy to adjust. The automatism always work.

El cierre actúa al recibir el impulso eléctrico. Si durante el periodo de apertura, el cierre eléctrico recibe corriente, no quedará bloqueado al cerrar la puerta y será necesario volver a abrir y cerrar la puerta para dejar el cierre eléctrico bloqueado de nuevo. Indicado para cerraduras con picaporte corto.

Electric door opener remains open until the door is opened. If during the opening period the electric strike receives current, it will not be locked when the door is closed and it will be necessary to reopen and close the door to leave the electric strike locked again. Indicated for locks with short latch.

Palanca continua (terminación de la referencia 36/46) / Lever pin (36/46 reference ending)

Facilidad de ajuste. El automatismo siempre se activa ya que la palanca actúa en toda la amplitud del picaporte.

Easy adjustment. The automatism is always activated since the lever works in the entire width of the latch.

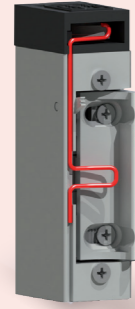

SEÑALIZACIÓN - MICRO / MONITORED

El cierre eléctrico integra un micro interruptor que indica el estado de puerta (abierta o cerrada). La señal del micro interruptor puede ser conectada a un sistema lumínico, sonoro, control de acceso o puertas exclusas.

The electric door opener integrates a micro switch that indicates the status of the door (open or closed). The signal of the micro switch can be connected to a lighting, sound system, access control or interlocking doors.

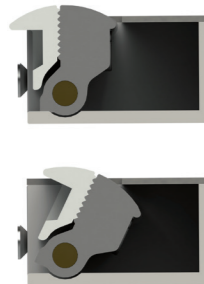

PESTILLO RADIAL / RADIAL LATCH

La forma del pestillo y la posición del eje de giro, permiten que este gire hacia el interior de la caja del cierre eléctrico, disminuyendo el corte necesario en el marco.

The shape of the latch and the position of the turning axis allows it to rotate towards the inside of the electric strike box, reducing the necessary cut in the frame.



RADIAL TOBOGÁN PARA PICAPORTE / RADIAL LATCH SLIDE

La forma radial y el tobogán de deslizamiento del picaporte, permiten una instalación sin corte en el marco.

The radial shape and latch slide allow an installation without cutting the frame.



PRECARGA / PRELOAD

Es la fuerza/presión externa, que se ejerce contra el pestillo del cierre eléctrico proveniente de las diferentes fuentes como viento, peso de la puerta, bandas de sellado o una mala instalación del producto.

It is the external force / pressure, which is exerted against the latch of the electric strike coming from different sources such as wind, door weight, sealing bands or a bad installation of the product.

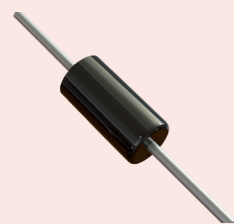

PROTECTION ELECTRÓNICA / ELECTRICAL PROTECTION

El diodo transil protege al sistema electrónico del retorno de puntas de tensión.

The diode transil protects the system from electrical spikes that can damage any access control system.

MANO / HAND

Solamente aplicable en modelos no reversibles. Es el sentido de apertura de la puerta, hacia la derecha o hacia la izquierda. Existen dos formas de determinar la mano, la norma tradicional y la norma DIN.

Only for non-reversible models. It is the door opening direction, right or left. There are two ways to determine the hand, the tradition way standard and the DIN norm.



Tradicional izquierda / Left Tradicional derecha / Right



Din izquierda / Left Din derecha / Right

COMO HACER UN PEDIDO
HOW TO ORDER

- 1 Escoger la serie. p.ej.: 1700
Chose the series. i.e.: 1700
- 2 Escoger la función. p.ej.: Con palanca de desbloqueo.1720
Chose the features i.e.: With release lever. 1720
- 3 Escoger el frontal en caso de que se solicite. p.ej.: 1720 / 902
Chose the front plate in case that is asked: i.e.: 1720 / 902
- 4 Escoger el material del frontal. p.ej.: Inoxidable: 1720 / 902 X
Chose the front plate finish: i.e.: Stainless Steel: 1720 / 902 X
- 5 Escoger la bobina. p.ej.: B 12-24 AC/DC
Chose the coil i.e.: B 12-24 AC/DC
- 6 Opcional: protección electrónica, añadir T al modelo de bobina
Optional: electronical protection, add T al coil reference

Ejemplo de pedido
Sin frontal : 1720 / B
Con frontal : 1720 902X / B
Con protección: 1720 902X / BT

Order example
Without front plate: 1720 / B
With front plate: 1720 902X / B
With protection: 1720 902X / BT



INICIAL / INITIAL
BÁSICO / BASIC
ECONÓMICO / ECONOMIC

Características técnicas / Technical specifications

Medidas / Dimensions	90 X 21 X 28,5 mm
Voltaje / Voltage	Según tabla de bobinas / According to the coils table
Pestillo ajustable / Adjustable latch	5 mm
Profundidad de pestillo / Latch bolt depth	7 mm
Resistencia a la rotura / Break-in resistance	3.000 N
Precarga / Preload	90 N 12 V AC / 10 N 12 V DC
Ciclos / Cycles	250.000
Reversible / Reversible	Si / Yes
Posición de instalación / Installation position	Vertical. Horizontal
Temperatura de trabajo / Operating temperature	-10°C + 60°C

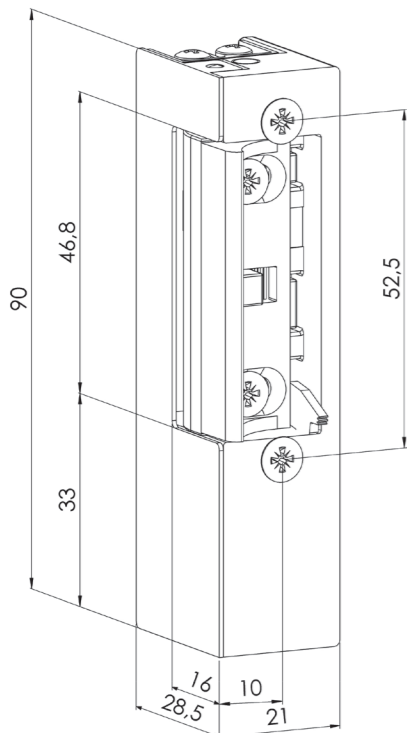

Frontales compatibles / Compatible front plates

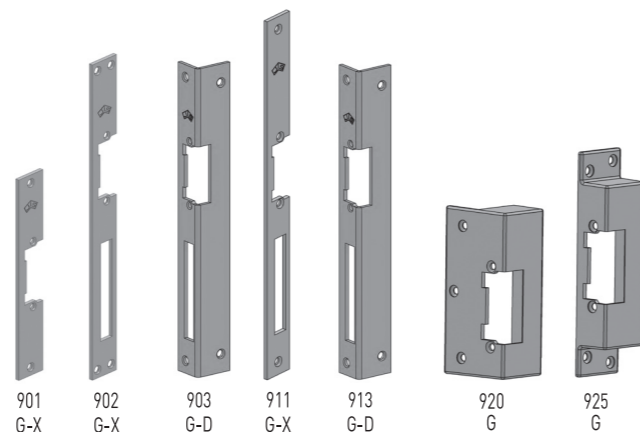

Funciones disponibles / Available features

Referencia	Pestillo ajustable	Estándar	Palanca desbloqueo	Memoria / Memory		Normal	Inverso
Reference	Adjustable latch	Standard	Releasing lever	Pin	Interna Internal	Fail secure	Fail safe
810		✓				✓	
812	✓	✓				✓	
820		✓	✓			✓	
822	✓	✓	✓			✓	
830				✓		✓	
832	✓			✓		✓	
833					✓	✓	
834	✓				✓	✓	
840			✓	✓		✓	
842	✓		✓	✓		✓	
843			✓		✓	✓	
844	✓		✓		✓	✓	
811	✓					✓	✓

Bobinas disponibles / Available coils

Bobinas / Coils	Normal / Fail secure		Inverso / Fail safe	
	A	B	E	F
Conexión eléctrica / Electrical power	12 V AC / DC	12-24 V AC / DC	12 V DC	24 V DC
Trabajo continuo / Continuous duty	<1'	<1' 12 V AC <1' 24 V AC / DC	100% DC	100% DC
Tensión nominal / Nominal voltage V	12 V AC	12 V AC	12 V DC	24 V DC
Resistencia / Resistance Ω	10	23	60	150
Consumo / Consumption AC / mA	12 V / 850	12 V / 450		
Consumo / Consumption DC / mA	12 V / 1200	12 V / 500	12 V / 200	
Consumo / Consumption AC / mA		24 V / 900		
Consumo / Consumption DC / mA		24 V / 1000		24 V / 160
Precarga / Preload AC / N	90	90		
Precarga / Preload DC / N	10	10	10	10
Tolerancia / Range	+/-10%			

Normativas / Norms

Compatibilidad electromagnética / Electromagnetic compatibility	Directiva 2014/ 30 / UE
RAEE	RII AEE 6783
Directiva de baja tensión / Low voltage directive	Directiva 2014/ 35 / UE
Sustancias peligrosas / Hazardous substances	Directiva 2011/ 65 / UE
Resistencia a la corrosión / Corrosion resistance	UNE-EN-1670
Herrajes edificación / Building hardware	UNE-EN-14846:2010 / UNE-EN-12209: 2009
DOP. Clasificación / Classification	Normal / Fail Secure 3 X 2 0 0 L 0 0 0 Inverso / Fail Safe 3 X 2 0 0 L 0 0 1



VERSÁTIL / VERSATILE
SIMÉTRICO / SYMMETRIC
AMPLIA GAMA / WIDE RANGE
REVERSIBLE / REVERSIBLE

Características técnicas / Technical specifications

Medidas / Dimensions	67 X 20,5 X 28,5 mm
Voltaje / Voltage	Según tabla de bobinas / According to the coils table
Pestillo ajustable / Adjustable latch	5 mm
Profundidad de pestillo / Latch bolt depth	7 mm
Resistencia a la rotura / Break-in resistance	3.000 N
Precarga / Preload	90 N 12 V AC / 10 N 12 V DC
Ciclos / Cycles	250.000
Reversible / Reversible	Simétrico / Symmetric
Posición de instalación / Installation position	Vertical. Horizontal
Temperatura de trabajo / Operating temperature	-10°C + 60°C
Protección eléctrica / Electrical protection	Opcional (transil) / Optional (transil)

Frontales compatibles / Compatible front plates

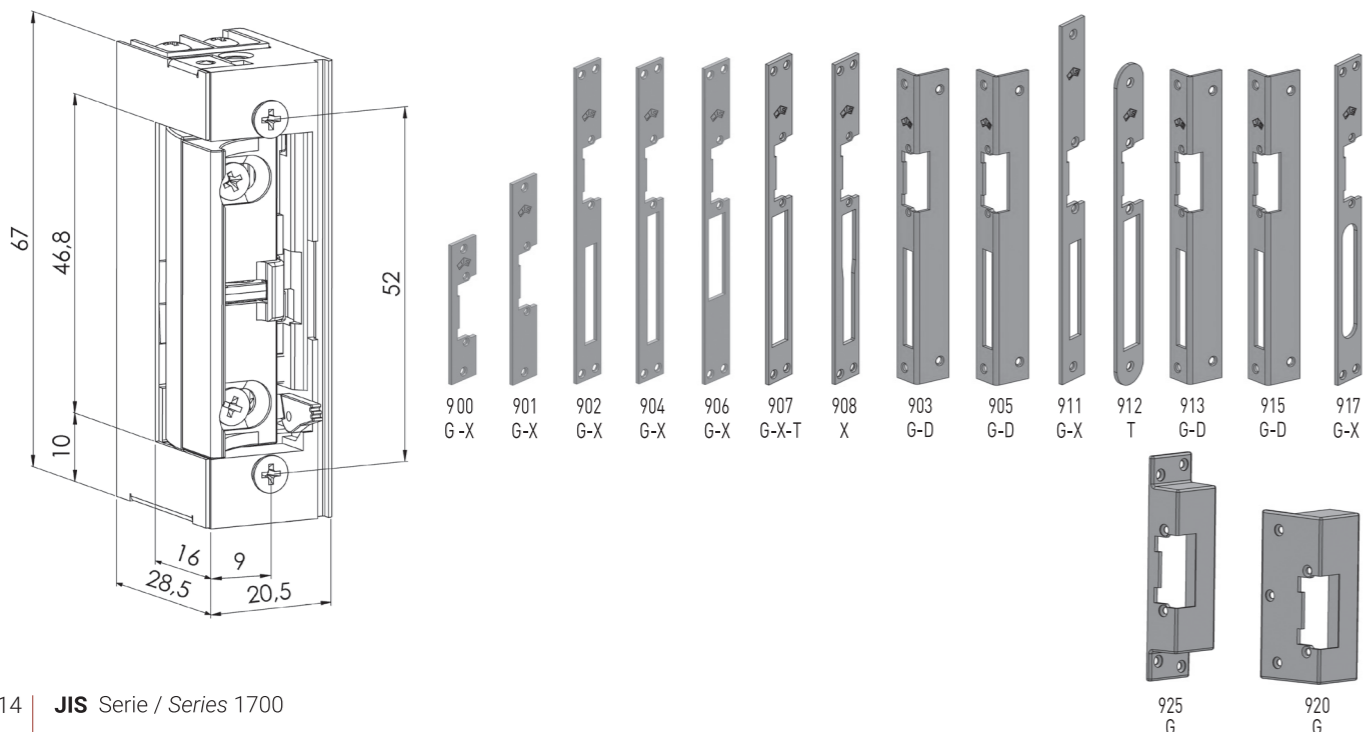

Funciones disponibles / Available features

Referencia	Pestillo ajustable	Estándar	Palanca desbloqueo	Memoria / Memory			Normal	Inverso
Reference	Adjustable latch	Standard	Releasing lever	Pin	Palanca Lever	Interna Internal	Fail secure	Fail safe
1710	✓	✓					✓	
1720	✓	✓	✓				✓	
1730	✓			✓			✓	
1733	✓					✓	✓	
1736	✓				✓		✓	
1740	✓		✓	✓			✓	
1743	✓		✓			✓	✓	
1746	✓		✓		✓		✓	
1711	✓							✓

Bobinas disponibles / Available coils

Bobinas / Coils	Normal / Fail secure				Inverso / Fail safe	
	A	B	C	D	E	F
Conexión eléctrica / Electrical power	6-12 V AC / DC	12-24 V AC / DC	12-24 V AC / DC	24-48 V AC / DC	12 V DC	24 V DC
Trabajo continuo / Continuous duty	<1'	<1'	100% 12 V DC	100% 24 V DC	100% DC	100% DC
Tensión nominal / Nominal voltage V	12 V AC	12 V AC	12 V AC	24 V AC	12 V DC	24 V DC
Resistencia / Resistance Ω	8,5	20	40	150	60	150
Consumo / Consumption AC / mA	6 V / 600	12 V / 500	12 V / 250	24 V / 130		
Consumo / Consumption DC / mA	6 V / 700	12 V / 600	12 V / 300	24 V / 160	12 V / 200	24 V / 160
Precarga / Preload AC / N	90	90	90	90		
Precarga / Preload DC / N	10	10	10	10	10	10
Tolerancia / Range	+/-10%					

Normativas / Norms

Compatibilidad electromagnética / Electromagnetic compatibility	Directiva 2014/ 30 / UE
RAEE	RII AEE 6783
Directiva de baja tensión / Low voltage directive	Directiva 2014/ 35 / UE
Sustancias peligrosas / Hazardous substances	Directiva 2011/ 65 / UE
Resistencia a la corrosión / Corrosion resistance	UNE-EN-1670
Herrajes edificación / Building hardware	UNE-EN-14846:2010 / UNE-EN-12209: 2009
DOP. Clasificación / Classification	Normal / Fail Secure 3 X 2 0 0 L 0 0 0 Inverso / Fail Safe 3 X 2 0 0 L 0 0 1

Serie Series 1700 MICRO / MONITORED

Serie Series 1700 BITENSIÓN. INVERSO / FAIL SAFE



SEÑALIZACIÓN / SIGNAL
REVERSIBLE / REVERSIBLE



INVERSO / FAIL SAFE
BITENSIÓN 12 Ó / OR 24 V DC
REVERSIBLE / REVERSIBLE

Características técnicas / Technical specifications

Medidas / Dimensions	78 mm X 20,5 mm X 28,5 mm
Voltaje / Voltage	Según tabla de bobinas / According to the coils table
Pestillo ajustable / Adjustable latch	5 mm
Profundidad de pestillo / Latch bolt depth	7 mm
Resistencia a la rotura / Break-in resistance	3.000 N
Precarga / Preload	90 N 12 V AC / 10 N 12 V DC
Ciclos / Cycles	250.000
Reversible / Reversible	Si / Yes
Posición de instalación / Installation position	Vertical. Horizontal
Temperatura de trabajo / Operating temperature	-10°C -- + 60°C
Protección eléctrica / Electrical protection	Opcional (Transil) / Optional (Transil)
Intensidad máxima / Maximum intensity. Microswitch	AC (125V) - 3A / DC (30V) - 2A

Funciones disponibles / Available features

Referencia	Pestillo ajustable	Estándar	Micro	Normal	Inverso
Reference	Adjustable latch	Standard	Monitored	Fail secure	Fail safe
1760	✓	✓	✓	✓	
1761	✓		✓		✓

*Consultar otras opciones / Ask for others options.

Bobinas disponibles / Available coils

Bobinas / Coils	Normal / Fail secure				Inverso / Fail safe	
	A	B	C	D	E	F
Conexión eléctrica / Electrical power	6-12 V AC / DC	12-24 V AC / DC	12-24 V AC / DC	24-48 V AC / DC	12 V DC	24 V DC
Trabajo continuo / Continuous duty	<1'	<1'	100% 12V DC	100% 24V DC	100% DC	100% DC
Tensión nominal / Nominal voltage V	12 V AC	12 V AC	<1' 12 V AC <1' 24V AC / DC	<1' 24 V AC <1' 48 V AC / DC	12 V DC	24 VDC
Resistencia / Resistance Ω	8,5	20	40	150	60	150
Consumo / Consumption AC / mA	6 V / 600	12 V / 500	12 V / 250	24 V / 150		
Consumo / Consumption DC / mA	6 V / 700	12 V / 600	12 V / 300	2.4V / 170	12 V / 300	
Consumo / Consumption AC / mA	12 V / 1200	24 V / 1100	24 V / 510	48 V / 300		
Consumo / Consumption DC / mA	12 V / 1400	24 V / 1100	24 V / 600	4.8V / 340		24 V / 170
Precarga / Preload AC / N	90	90	90	90		
Precarga / Preload DC / N	10	10	10	10	10	10
Tolerancia / Range	+/-10%					

**FRONTALES COMPATIBLES. Ver serie 1700 / COMPATIBLE FRONT PLATES. See 1700 series

Características técnicas / Technical specifications

Medidas / Dimensions	76,5 mm X 20,5 mm X 28,5 mm
Voltaje / Voltage	12-24 V DC (jumper)
Pestillo ajustable / Adjustable latch	5 mm
Profundidad de pestillo / Latch bolt depth	7 mm
Resistencia a la rotura / Break-in resistance	3.000 N
Precarga / Preload	10 N 12 V DC
Ciclos / Cycles	250.000
Reversible / Reversible	Si / Yes
Posición de instalación / Installation position	Vertical. Horizontal
Temperatura de trabajo / Operating temperature	-10°C -- + 60°C
Protección eléctrica / Electrical protection	Transil / Transil

Funciones disponibles / Available features

Referencia	Antipánico	Pestillo ajustable	Estándar	Micro	Normal	Inverso
Reference	Antipanic	Adjustable latch	Standard	Monitored	Fail secure	Fail safe
1711-BI		✓				✓
1761-BI		✓		✓		✓
1771-BI	✓					✓
1791-BI	✓			✓		✓

Bobinas disponibles / Available coils

Bobinas / Coils	Inverso / Fail safe
	V
Conexión eléctrica / Electrical power	12-24 V DC
Trabajo continuo / Continuous duty	100% 12 ó / or 24 V DC
Tensión nominal / Nominal voltage V	12 ó/or 24 VDC (Jumper)
Resistencia / Resistance Ω	45 / 180
Consumo / Consumption DC / mA	12 V / 260
Consumo / Consumption DC / mA	24 V / 130
Precarga / Preload DC / N	10
Tolerancia / Range	+/-10%

**FRONTALES COMPATIBLES. Ver serie 1700 / COMPATIBLE FRONT PLATES. See 1700 series

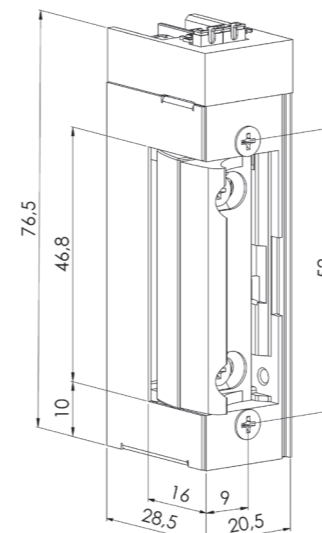
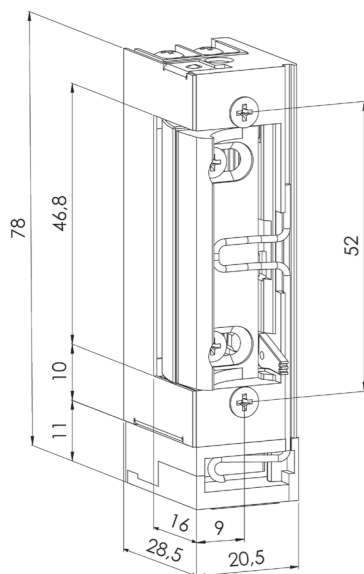

Serie Series 1700 SILENT



SILENCIOSO / SILENCE
DISCRETO / DISCRET

PRECARGA / PRELOAD 200N

Serie Series 1700 BUZZER



ZUMBADOR / BUZZER
CIERRE EN DC
DOOR OPENER IN DC

Características técnicas / Technical specifications

Medidas / Dimensions	67 mm X 20,5 mm X 28,5 mm
Voltaje / Voltage	Según tabla de bobinas / According to the coils table
Pestillo ajustable / Adjustable latch	5 mm
Profundidad de pestillo / Latch bolt depth	7 mm
Resistencia a la rotura / Break-in resistance	3.000 N
Precarga / Preload	200 N 12 V AC
Ciclos / Cycles	250.000
Reversible / Reversible	Simétrico / Symmetric
Posición de instalación / Installation position	Vertical. Horizontal
Temperatura de trabajo / Operating temperature	-10°C -- + 60°C
Protección eléctrica / Electrical protection	Opcional (Transil) / Optional (Transil)

Funciones disponibles / Available features

Referencia	Pestillo ajustable	Estándar	Palanca desbloqueo	Memoria / Memory			Normal
Reference	Adjustable latch	Standard	Releasing lever	Pin	Palanca Lever	Interna Internal	Fail secure
1710 SILENT	✓	✓					✓
1720 SILENT	✓	✓	✓				✓
1730 SILENT	✓			✓			✓
1733 SILENT	✓					✓	✓
1736 SILENT	✓				✓		✓
1740 SILENT	✓		✓	✓			✓
1743 SILENT	✓		✓			✓	✓
1746 SILENT	✓		✓		✓		✓

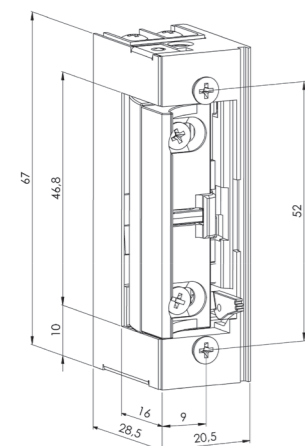

Bobinas disponibles / Available coils

Bobinas / Coils	Normal / Fail secure	
	AS	BS
Conexión eléctrica / Electrical power	10-12 V AC	22-24 V AC
Tolerancia / Range	+/-10%	+/-10%
Voltage nominal / Nominal voltage V	12 V AC	24 V AC
Resistencia / Resistance Ω	8,5	20
Consumo / Consumption 12 AC	600	
Consumo / Consumption 24 AC		1000
Precarga / Preload AC / N		200
Precarga / Preload DC / N		10
Tolerancia / Range	+/-10%	

** FRONTALES COMPATIBLES. Ver serie 1700
COMPATIBLE FRONT PLATES. See 1700 Series

Características técnicas / Technical specifications

Medidas / Dimensions	76,5 mm X 20,5 mm X 28,5 mm
Voltaje / Voltage	Según tabla de bobinas / According to the coils table
Pestillo ajustable / Adjustable latch	5 mm
Profundidad de pestillo / Latch bolt depth	7 mm
Resistencia a la rotura / Break-in resistance	3.000 N
Precarga / Preload	10 N 12 V DC
Ciclos / Cycles	250.000
Reversible / Reversible	Simétrico / Symmetric
Posición de instalación / Installation position	Vertical. Horizontal
Temperatura de trabajo / Operating temperature	-10°C -- + 60°C
Protección eléctrica / Electrical protection	Opcional (Transil) / Optional (Transil)
Polaridad / Polarity	Si / Yes

Funciones disponibles / Available features

Referencia	Pestillo ajustable	Estándar	Palanca desbloqueo	Memoria / Memory			Normal
Reference	Adjustable latch	Standard	Releasing lever	Pin	Palanca Lever	Interna Internal	Fail secure
1710 BUZZER	✓	✓					✓
1720 BUZZER	✓	✓	✓				✓
1730 BUZZER	✓			✓			✓
1733 BUZZER	✓					✓	✓
1736 BUZZER	✓				✓		✓
1740 BUZZER	✓		✓	✓			✓
1743 BUZZER	✓		✓			✓	✓
1746 BUZZER	✓		✓		✓		✓

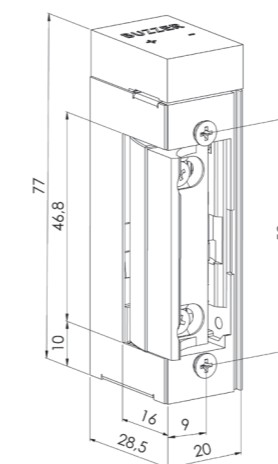

Bobinas disponibles / Available coils

Bobinas / Coils	Normal / Fail secure	
	BB	
Conexión Eléctrica / Electrical power	12-24 V DC	
Tolerancia / Range	+/-10%	
Tensión nominal / Nominal voltage V	12 V DC	
Resistencia / Resistance Ω	20	
Consumo / Consumption DC mA	12 V / 600	
Consumo / Consumption DC mA	24 V / 1400	
Precarga / Preload DC / N	10	
Tolerancia / Range	+/-10%	

** FRONTALES COMPATIBLES. Ver serie 1700
COMPATIBLE FRONT PLATES. See 1700 Series



ESTRECHO / NARROW
SIMÉTRICO / SYMMETRIC
REVERSIBLE / REVERSIBLE
PARA / FOR PVC & ALUM

Características técnicas / Technical specifications

Medidas / Dimensions	67 X 16,5 X 28,5 mm
Voltaje / Voltage	Según tabla de bobinas / According to the coils table
Pestillo ajustable / Adjustable latch	4 mm
Profundidad de pestillo / Latch bolt depth	7 mm
Resistencia a la rotura / Break-in resistance	3.000 N
Precarga / Preload	90 N 12 V AC / 10 N 12 V DC
Ciclos / Cycles	250.000
Reversible / Reversible	Simétrico / Symmetric
Posición de instalación / Installation position	Vertical. Horizontal
Temperatura de trabajo / Operating temperature	-10°C + 60°C
Protección eléctrica / Electrical protection	Opcional (Transil) / Optional (Transil)

Frontales compatibles / Compatible front plates

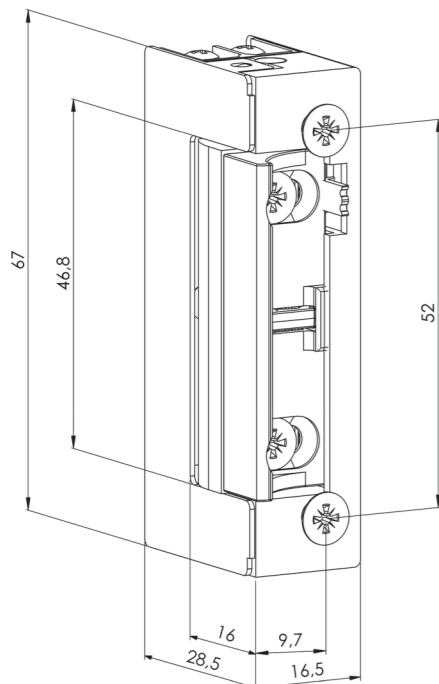

* Frontal / Front plate 22 mm

Funciones disponibles / Available features

Referencia	Pestillo ajustable	Estándar	Palanca desbloqueo	Memoria / Memory			Normal	Inverso
Reference	Adjustable latch	Standard	Releasing lever	Pin	Palanca Lever	Interna Internal	Fail secure	Fail safe
1410	✓	✓					✓	
1420	✓	✓	✓				✓	
1430	✓			✓			✓	
1433	✓					✓	✓	
1436	✓				✓		✓	
1440	✓		✓	✓			✓	
1443	✓		✓			✓	✓	
1446	✓		✓		✓			
1411	✓							✓

Bobinas disponibles / Available coils

Bobinas / Coils	Normal / Fail secure				Inverso / Fail safe	
	A	B	C	D	E	F
Conexión eléctrica / Electrical power	6-12 V AC/DC	12-24 V AC/DC	12-24 V AC/DC	24-48 V AC/DC	12 V DC	24 V DC
Trabajo continuo / Continuous duty			100% 12V DC	100% 24V DC	100% DC	100% DC
	<1'	<1'	<1' 12 V AC <1' 24 V AC / DC	<1' 24 V AC <1' 48 V AC / DC	12 V DC	24 V DC
Tensión nominal / Nominal voltage V	12 V AC	12 V AC	12 V AC	24 V AC	12 V DC	24 V DC
Resistencia / Resistance Ω	8,5	20	40	140	40	140
Consumo / Consumption AC / mA	6 V / 600	12 V / 500	12 V / 250	24 V / 150		
Consumo / Consumption DC / mA	6 V / 700	12 V / 600	12 V / 300	24 V / 170	12 V / 300	
Consumo / Consumption AC / mA	12 V / 1200	24 V / 1100	24 V / 510	48 V / 300		
Consumo / Consumption DC / mA	12 V / 1400	24 V / 1100	24 V / 600	48 V / 340		24 V / 170
Precarga / Preload AC / N	90	90	90	90		
Precarga / Preload DC / N	10	10	10	10	10	10
Tolerancia / Range	+/-10%					

Normativas / Norms

Compatibilidad electromagnética / Electromagnetic compatibility	Directiva 2014/ 30 / UE
RAEE	RII AEE 6783
Directiva de baja tensión / Low voltage directive	Directiva 2014/ 35 / UE
Sustancias peligrosas / Hazardous substances	Directiva 2011/ 65 / UE
Resistencia a la corrosión / Corrosion resistance	UNE-EN-1670
Herrajes edificación / Building hardware	UNE-EN-14846:2010 / UNE-EN-12209: 2009
DOP. Clasificación / Classification	Normal / Fail Secure 3 X 2 0 0 L 0 0 0 Inverso / Fail Safe 3 X 2 0 0 L 0 0 1

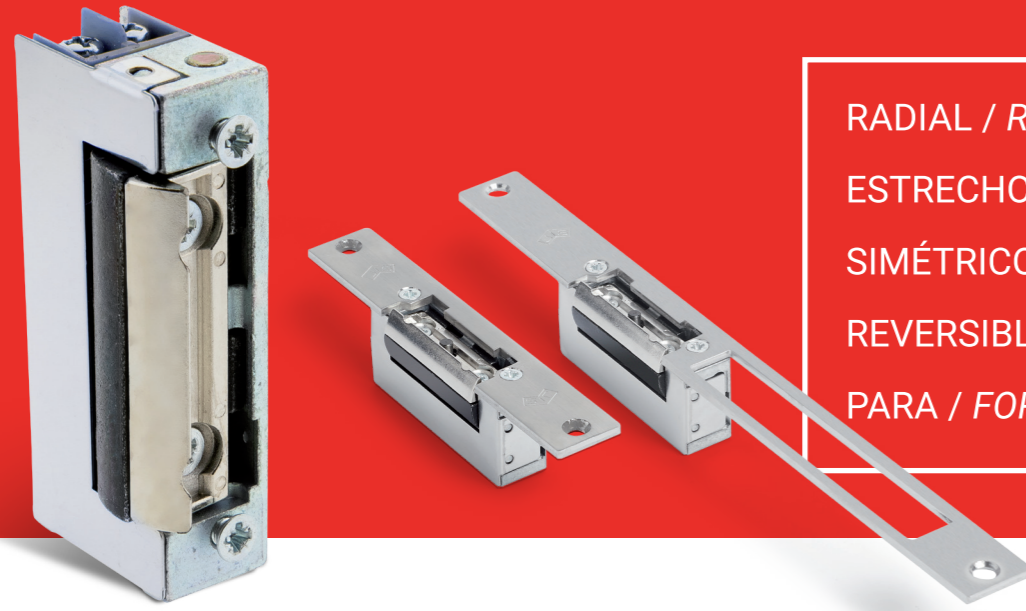

RADIAL / RADIAL
 ESTRECHO / NARROW
 SIMÉTRICO / SYMMETRIC
 REVERSIBLE / REVERSIBLE
 PARA / FOR PVC & ALUM

Características técnicas / Technical specifications

Medidas / Dimensions	67 X 16,5 X 28,5 mm
Voltaje / Voltage	Según tabla de bobinas / According to the coils table
Pestillo ajustable / Adjustable lach	2 mm
Profundidad de pestillo / Latch bolt depth	5 mm
Resistencia a la rotura / Break-in resistance	3.000 N
Precarga / Preload	90 N 12 V AC / 10 N 12 V DC
Ciclos / Cycles	250.000
Reversible / Reversible	Simétrico / Symmetric
Posición de instalación / Installation position	Vertical. Horizontal
Temperatura de trabajo / Operating temperature	-10°C + 60°C
Protección eléctrica / Electrical protection	Opcional (Transil) / Optional (Transil)

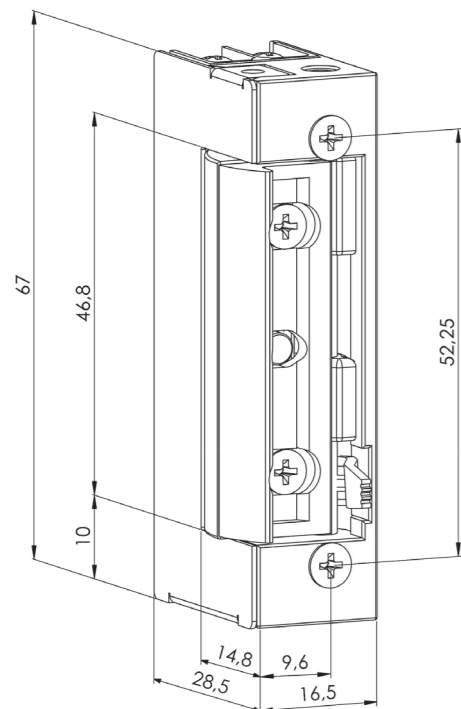

Movimiento radial
Radial movement



Corte normal
Normal curt



NOR

Corte reducido
Reduced curt



R

Frontales compatibles
Compatible front plates



909
G-X 910
G-X

* Frontal / Front plate 22 mm

Funciones disponibles / Available features

Referencia	Pestillo ajustable	Estándar	Palanca desbloqueo	Memoria / Memory		Normal	Inverso
Reference	Adjustable lach	Standard	Releasing lever	Pin	Interna Internal	Fail secure	Fail safe
1410 R	✓	✓				✓	
1420 R	✓	✓	✓			✓	
1430 R	✓			✓		✓	
1433 R	✓				✓	✓	
1440 R	✓		✓	✓		✓	
1443 R	✓		✓		✓	✓	
1411 R	✓						✓

Bobinas disponibles / Available coils

Bobinas / Coils	Normal / Fail secure				Inverso / Fail safe	
	A	B	C	D	E	F
Conexión eléctrica Electrical power	6-12 V AC / DC	12-24 V AC / DC	12-24 V AC / DC	24-48 V AC / DC	12 V DC	24 V DC
Trabajo continuo / Continuous duty			100% 12V DC	100% 24V DC	100% DC	100% DC
	<1'	<1'	<1' 12V AC <1' 24V AC / DC	<1' 24V AC <1' 48V AC / DC	12 VDC	24 VDC
Tensión nominal / Nominal voltage V	12 V AC	12 V AC	12 V AC	24V AC	12 V DC	24 V DC
Resistencia / Resistance Ω	8,5	20	40	140	40	140
Consumo / Consumption AC / mA	6 V / 600	12 V / 500	12 V / 250	24V / 150		
Consumo / Consumption DC / mA	6 V / 700	12 V / 600	12 V / 300	24 V / 170	12 V / 300	
Consumo / Consumption AC / mA	12 V / 1200	24 V / 1100	24 V / 510	48 V / 300		
Consumo / Consumption DC / mA	12 V / 1400	24 V / 1100	24 V / 600	48 V / 340		24 V / 170
Precarga / Preload AC / N	90	90	90	90		
Precarga / Preload DC / N	10	10	10	10	10	10
Tolerancia / Range	+/-10%					

Normativas / Norms

Compatibilidad electromagnética / Electromagnetic compatibility	Directiva 2014/ 30 / UE
RAEE	RII AEE 6783
Directiva de baja tensión / Low voltage directive	Directiva 2014/ 35 / UE
Sustancias peligrosas / Hazardous substances	Directiva 2011/ 65 / UE
Resistencia a la corrosión / Corrosion resistance	UNE-EN-1670
Herrajes edificación / Building hardware	UNE-EN-14846:2010 / UNE-EN-12209: 2009
DOP. Clasificación / Classification	Normal / Fail Secure 3 X 2 0 0 L 0 0 0
	Inverso / Fail Safe 3 X 2 0 0 L 0 0 1

Serie Series 1400 RT

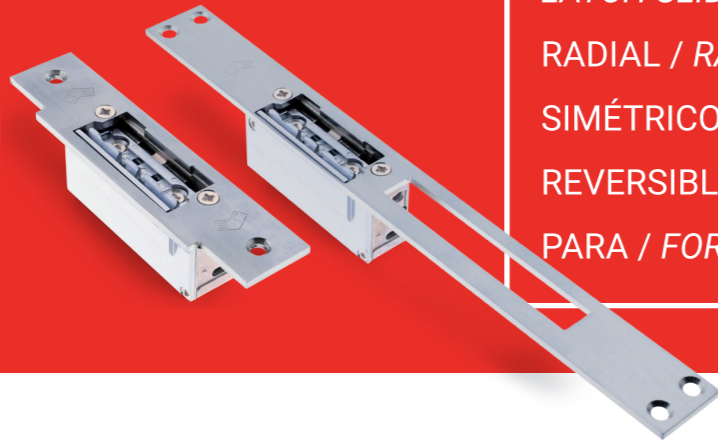

TOBOGÁN PARA PICAPORTE
LATCH SLIDE
RADIAL / RADIAL
SIMÉTRICO / SYMMETRIC
REVERSIBLE / REVERSIBLE
PARA / FOR PVC & ALUM

Características técnicas / Technical specifications

Medidas / Dimensions	67 mm X 20,8 mm X 28,5 mm
Voltaje / Voltage	Según tabla de bobinas / According to the coils table
Pestillo ajustable / Adjustable latch	2 mm
Profundidad de pestillo / Latch bolt depth	5 mm
Resistencia a la rotura / Break-in resistance	3.000 N
Precarga / Preload	90 N 12 V AC / 10 N 12 V DC
Ciclos / Cycles	250.000
Reversible / Reversible	Simétrico / Symmetric
Posición de instalación / Installation position	Vertical. Horizontal
Temperatura de trabajo / Operating temperature	-10°C + 60°C
Protección eléctrica / Electrical protection	Opcional (Transil) / Optional (Transil)

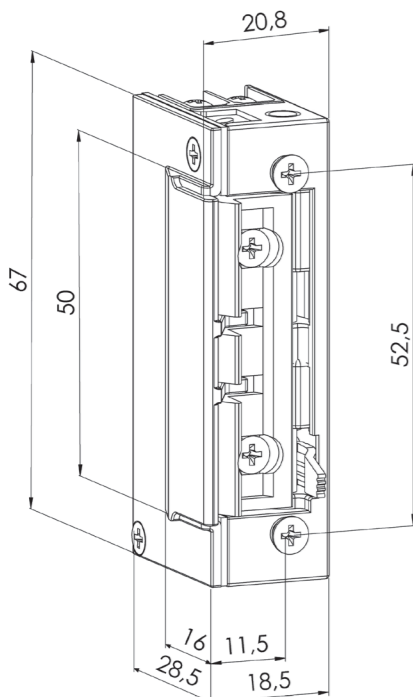

El pestillo se desliza sobre el toboacán de la tapa
The latch slides on the cover



*Sin corte en el marco
*No need to cut the frame

Frontales compatibles
Compatible front plates



Funciones disponibles / Available features

Referencia	Pestillo ajustable	Estándar	Palanca desbloqueo	Memoria / Memory		Normal	Inverso
Reference	Adjustable latch	Standard	Releasing lever	Pin	Interna Internal	Fail secure	Fail safe
1410 RT	✓	✓				✓	
1420 RT	✓	✓	✓			✓	
1430 RT	✓			✓		✓	
1433 RT	✓				✓	✓	
1440 RT	✓		✓	✓		✓	
1443 RT	✓		✓		✓	✓	
1411 RT	✓						✓

Bobinas disponibles / Available coils

Bobinas / Coils	Normal / Fail secure				Inverso / Fail safe	
	A	B	C	D	E	F
Conexión eléctrica Electrical power	6-12 V AC / DC	12-24 V AC / DC	12-24 V AC / DC	24-48 V AC / DC	12 V DC	24 V DC
Trabajo continuo / Continuous duty			100% 12 V DC	100% 24 V DC	100% DC	
	<1'	<1'	<1' 12 V AC <1' 24 V AC / DC	<1' 24 V AC <1' 48V AC / DC	12 VDC	24 VDC
Tensión nominal / Nominal voltage V	12 V AC	12 V AC	12 V AC	24 V AC	12 V DC	24 V DC
Resistencia / Resistance Ω	8,5	20	40	140	40	140
Consumo / Consumption AC / mA	6 V / 600	12 V / 500	12 V / 250	24 V / 150		
Consumo / Consumption DC / mA	6 V / 700	12 V / 600	12 V / 300	24 V / 170	12 V / 300	
Consumo / Consumption AC / mA	12 V / 1200	24 V / 1100	24 V / 510	48 V / 300		
Consumo / Consumption DC / mA	12 V / 1400	24 V / 1100	24 V / 600	48 V / 340		24 V / 170
Precarga / Preload AC / N	90	90	90	90		
Precarga / Preload DC / N	10	10	10	10	10	10
Tolerancia / Range	+/-10%					

Normativas / Norms

Compatibilidad electromagnética / Electromagnetic compatibility	Directiva 2014/ 30 / UE
RAEE	RII AEE 6783
Directiva de baja tensión / Low voltage directive	Directiva 2014/ 35 / UE
Sustancias peligrosas / Hazardous substances	Directiva 2011/ 65 / UE
Resistencia a la corrosión / Corrosion resistance	UNE-EN-1670
Herrajes edificación / Building hardware	UNE-EN-14846:2010 / UNE-EN-12209: 2009
DOP. Clasificación / Classification	Normal / Fail Secure 3 X 2 0 0 L 0 0 0 Inverso / Fail Safe 3 X 2 0 0 L 0 0 1

Serie 1480 RF Resistente al fuego

Series 1480 RFT Fire resistance



PARA PUERTAS
RESISTENTES AL FUEGO
FOR FIRE PROOF DOORS

RADIAL ESTRECHO
NARROW 16 mm

PARA TOBOGÁN PARA
PICAPORTE
LATCH SLIDE

Características técnicas / Technical specifications

Medidas / Dimensions	RF 67 X 31,9 X 16 mm RFT 67 X 31,9 X 21,3 mm
Voltaje / Voltage	Según tabla de bobinas / According to the coils table
Pestillo ajustable / Adjustable latch	1,5 mm
Profundidad de pestillo / Latch bolt depth	5 mm
Resistencia a la rotura / Break-in resistance	5.000 N
Precarga / Preload	90 N 12 V AC / 10 N 12 V DC
Ciclos / Cycles	250.000
Reversible / Reversible	Simétrico / Symmetric
Posición de instalación / Installation position	Vertical. Horizontal
Temperatura de trabajo / Operating temperature	-10°C -- + 60°C
Protección eléctrica / Electrical protection	Opcional (Transil) / Optional (Transil)
Resistencia al fuego / Fire resistance	60 m a 1.200 °C

El pestillo se desliza sobre el
tobogán de la tapa
The latch slides on the cover



NO RFT

RF

*Sin corte en el marco
* No need to cut the frame

Frontales compatibles Compatible front plates

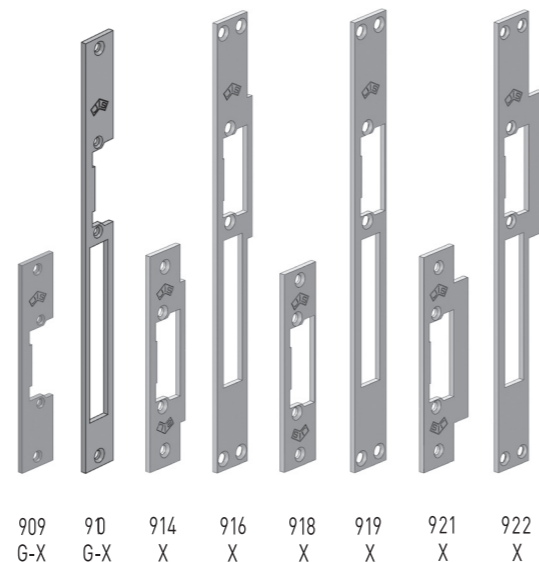

909 G-X
910 G-X
914 X
916 X
918 X
919 X
921 X
922 X

Funciones disponibles / Available features

Referencia	Pestillo ajustable	Estándar	Micro	Normal	Inverso
Reference	Adjustable latch	Standard	Monitored	Fail secure	Fail safe
1480 RF	✓	✓		✓	
1481 RF	✓				✓
1490 RF	✓	✓	✓	✓	
1491 RF	✓		✓		✓
1480 RFT	✓	✓		✓	
1481 RFT	✓				✓
1490 RFT	✓	✓	✓	✓	
1491 RFT	✓		✓		✓

Bobinas disponibles / Available coils

Bobinas / Coils	Normal / Fail secure		Inverso / Fail safe	
	B	E	F	
Conexión eléctrica / Electrical power	12-24 V AC / DC		12 V DC	24 V DC
Trabajo continuo / Continuous duty	<1'		100 % 12 V DC	
Tensión nominal / Nominal voltage V	12 V AC		12 V DC	24 V DC
Resistencia / Resistance Ω	20		40	140
Consumo / Consumption AC / mA	12 V / 500			
Consumo / Consumption DC / mA	12 V / 600		12 V / 300	
Consumo / Consumption AC / mA	24 V / 1000			
Consumo / Consumption DC / mA	24 V / 1100			24 V / 170
Precarga / Preload AC / N	90			
Precarga / Preload DC / N	10		10	10
Tolerancia / Range	+/-10%			

Normativas / Norms

Certificado Fuego / Fire Certificate	Nº 1488-CPR-055/W	
Compatibilidad electromagnética / Electromagnetic compatibility	Directiva 2014/ 30 / UE	
RAEE	RII AEE 6783	
Directiva de baja tensión / Low voltage directive	Directiva 2014/ 35 / UE	
Directiva resistencia fuego / Fire resistance	Directiva nº 14846: 2008	
Sustancias peligrosas / Hazardous substances	Directiva 2011/ 65 / UE	
Resistencia a la corrosión / Corrosion resistance	UNE-EN-1670	
Herrajes edificación / Building hardware	UNE-EN-14846:2010 / UNE-EN-12209: 2009	
DOP. Clasificación / Classification	Normal / Fail Secure	3 C 7 D - 0 4 0 0
	Inverso / Fail Safe	3 C 7 D - 0 3 0 1

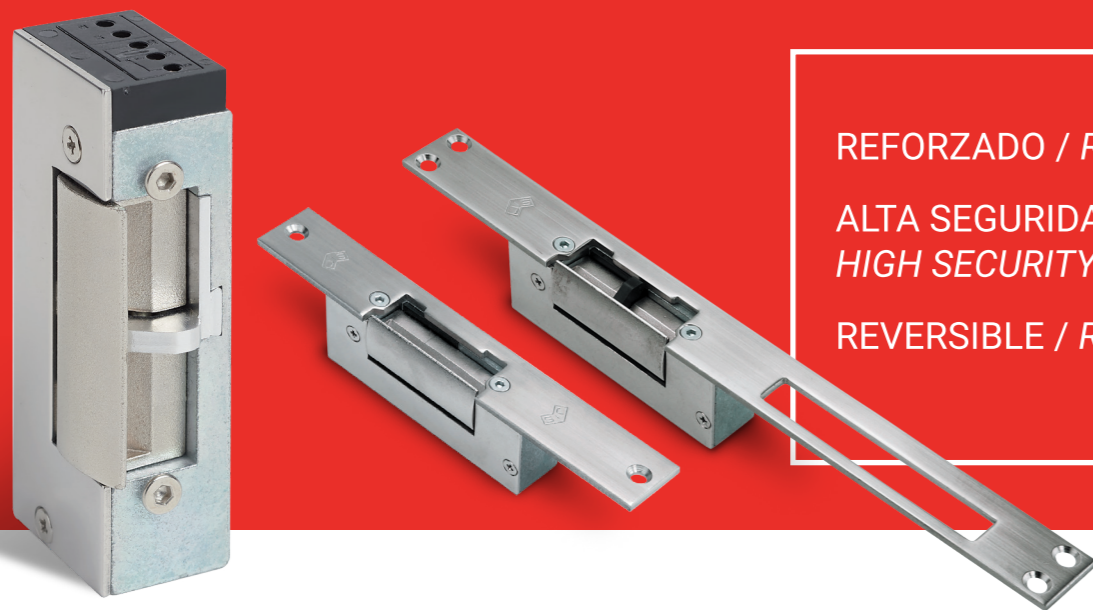

REFORZADO / REINFORCED

ALTA SEGURIDAD / HIGH SECURITY

REVERSIBLE / REVERSIBLE

1000 KG

Características técnicas / Technical specifications

Medidas / Dimensions	84,2 X 21,5 X 29,5 mm
Voltaje / Voltage	Según tabla de bobinas / According to the coils table
Pestillo ajustable / Adjustable latch	No
Profundidad de pestillo / Latch bolt depth	5 mm
Resistencia a la rotura / Break-in resistance	10.000 N
Precarga / Preload	90 N 12 V AC / 10 N 12 V DC
Ciclos / Cycles	250.000
Reversible / Reversible	Simétrico / Symmetric
Posición de instalación / Installation position	Vertical. Horizontal
Temperatura de trabajo / Operating temperature	-10°C + 60°C
Intensidad máxima / Maximum intensity. Microswitch	AC (125 V) - 3A / DC (30 V) - 2A

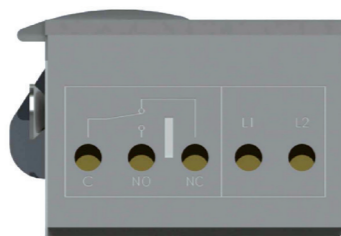
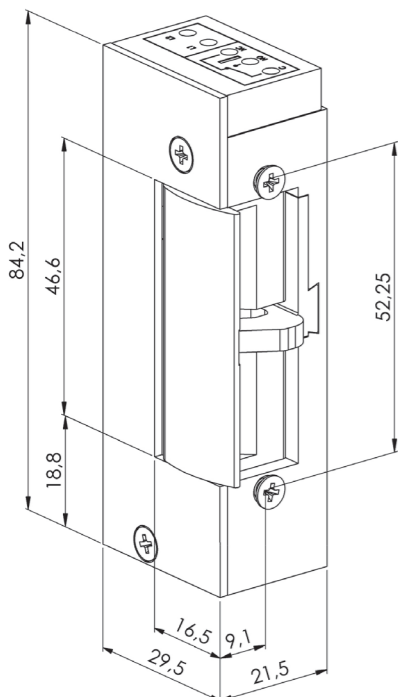

- L1 Entrada / Input
- L2 Entrada / Input
- NC
- COM Común / Common
- NO

*NC. Normalmente cerrado / Normally close
**NO. Normalmente abierto / Normally open

Frontales compatibles / Compatible front plates



Funciones disponibles / Available features

Referencia	Estándar	Memoria interna	Micro	Normal	Inverso
Reference	Standard	Internal memory	Monitored	Fail secure	Fail safe
1510	✓			✓	
1533		✓		✓	
1560			✓	✓	
1563		✓	✓	✓	
1511					✓
1561			✓		✓

* Activador del micro metálico, en opción.
* Optional metallic micro trigger.

Bobinas disponibles / Available coils

Bobinas / Coils	Normal / Fail secure				Inverso / Fail safe	
	A	B	C	D	E	F
Conexión eléctrica / Electrical power	6-12 V AC / DC	12-24 V AC / DC	12-24 V AC / DC	24-48 V AC / DC	12 V DC	24 V DC
Trabajo continuo / Continuous duty	<1'	<1'	100% 12 V DC	100% 24 V DC	100% DC	
Tensión nominal / Nominal voltage V	12 V AC	12 V AC	<1' 12 V AC <1' 24 V AC / DC	<1' 24 V AC <1' 48 V AC / DC	12 V DC	24 V DC
Resistencia / Resistance Ω	8,5	20	40	150	60	150
Consumo / Consumption AC / mA	6 V / 600	12 V / 500	12 V / 250	24 V / 150		
Consumo / Consumption DC / mA	6 V / 700	12 V / 600	12 V / 300	24 V / 170	12 V / 300	
Consumo / Consumption AC / mA	12 V / 1200	24 V / 1100	24 V / 510	48 V / 300		
Consumo / Consumption DC / mA	12 V / 1400	24 V / 1100	24 V / 600	48 V / 340		24 V / 170
Precarga / Preload AC / N	90	90	90	90		
Precarga / Preload DC / N	10	10	10	10	10	10
Tolerancia / Range	+/-10%					

Normativas / Norms

Compatibilidad electromagnética / Electromagnetic compatibility	Directiva 2014/ 30 / UE
RAEE	RII AEE 6783
Directiva de baja tensión / Low voltage directive	Directiva 2014/ 35 / UE
Sustancias peligrosas / Hazardous substances	Directiva 2011/ 65 / UE
Resistencia a la corrosión / Corrosion resistance	UNE-EN-1670
Herrajes edificación / Building hardware	UNE-EN-14846:2010 / UNE-EN-12209: 2009
DOP. Clasificación / Classification	Normal / Fail Secure 3 X 3 0 0 L 0 0 0 Inverso / Fail Safe 3 X 3 0 0 L 0 0 1

Serie 1580 RF Resistente al fuego

Series Fire resistance



PARA PUERTAS RESISTENTES AL FUEGO
FOR FIREPROOF DOORS

Serie Sobreponer / RIM

Series

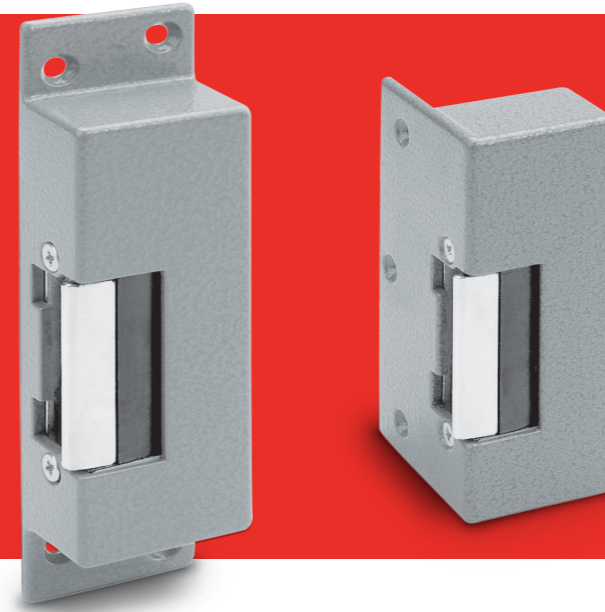

SIN RECEPTOR DE PESTILLO
ONLY LATCH

PARA SERIES
FOR SERIES 800 / 1700

Características técnicas / Technical specifications

Medidas / Dimensions	84,2 mm X 22,5 mm X 29,5 mm
Voltaje / Voltage	Según tabla de bobinas / According to the coils table
Pestillo ajustable / Adjustable latch	No
Profundidad de pestillo / Latch bolt depth	5 mm
Resistencia a la rotura / Break-in resistance	7.500 N
Precarga / Preload	90 N 12 V AC / 10 N 12 V DC
Ciclos / Cycles	250.000
Reversible / Reversible	Simétrico / Symmetric
Posición de instalación / Installation position	Vertical. Horizontal
Temperatura de trabajo / Operating temperature	-10°C -- + 60°C
Protección eléctrica / Electrical protection	Opcional (Transil) / Optional (Transil)
Resistencia al fuego / Fire resistance	60 m a 1.200 °C

Funciones disponibles / Available features

Referencia	Estándar	Normal	Inverso
Reference	Standard	Fail secure	Fail safe
1580 RF	✓	✓	
1581 RF			✓

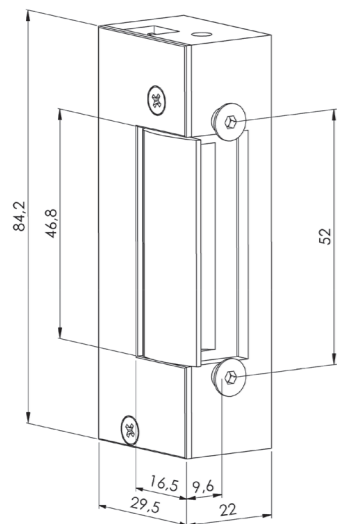

Bobinas disponibles / Available coils

Bobinas / Coils	Normal / Fail secure		Inverso / Fail safe	
	B	C	E	F
Conexión eléctrica / Electrical power	12-24 V AC / DC	12-24 V AC / DC	12 V DC	24 V DC
Trabajo continuo / Continuous duty	100 % 12 V DC			
	<1'	<1' 12 V AC <1' 24 V AC / DC	12 V DC	24 V DC
Tensión nominal / Nominal voltage V	12 V AC	12 V AC	12 V DC	24 V DC
Resistencia / Resistance Ω	20	40	60	150
Consumo / Consumption AC / mA	12 V / 500	12 V / 250		
Consumo / Consumption DC / mA	12 V / 600	12 V / 300	12 V / 200	
Consumo / Consumption AC / mA	24 V / 1000	24 V / 510		
Consumo / Consumption DC / mA	24 V / 1100	24 V / 600		24 V / 170
Precarga / Preload AC / N	90	90		
Precarga / Preload DC / N	10	10	10	10
Tolerancia / Range	+/-10%			

Normativas / Norms

Certificado Fuego / Fire Certificate	Nº 1488-CPR-055/W
Compatibilidad electromagnética / Electromagnetic compatibility	Directiva 2014/ 30 / UE
RAEE	RII AEE 6783
Directiva de baja tensión / Low voltage directive	Directiva 2014/ 35 / UE
Directiva resistencia fuego / Fire resistance	Directiva nº 14846: 2008
Sustancias peligrosas / Hazardous substances	Directiva 2011/ 65 / UE
Resistencia a la corrosión / Corrosion resistance	UNE-EN-1670
Herrajes edificación / Building hardware	UNE-EN-14846:2010 / UNE-EN-12209: 2009
DOP. Clasificación / Classification	Normal / Fail Secure 3 C 7 D - 0 4 0 0 Inverso / Fail Safe 3 C 7 D - 0 4 0 1

Características técnicas / Technical specifications

	Horizontal 920
Medidas / Dimensions	90 X 50 X 52 mm
Compatible con series / Compatible with series	800 -1700
Reversible / Reversible	Si / Yes
Acabado / Finishing	Gris / Grey

	Horizontal 925
Medidas / Dimensions	120 X 50 X 52 mm
Compatible con series / Compatible with series	800 -1700
Reversible / Reversible	Si / Yes
Acabado / Finishing	Gris / Grey

Dimensiones / Dimensions

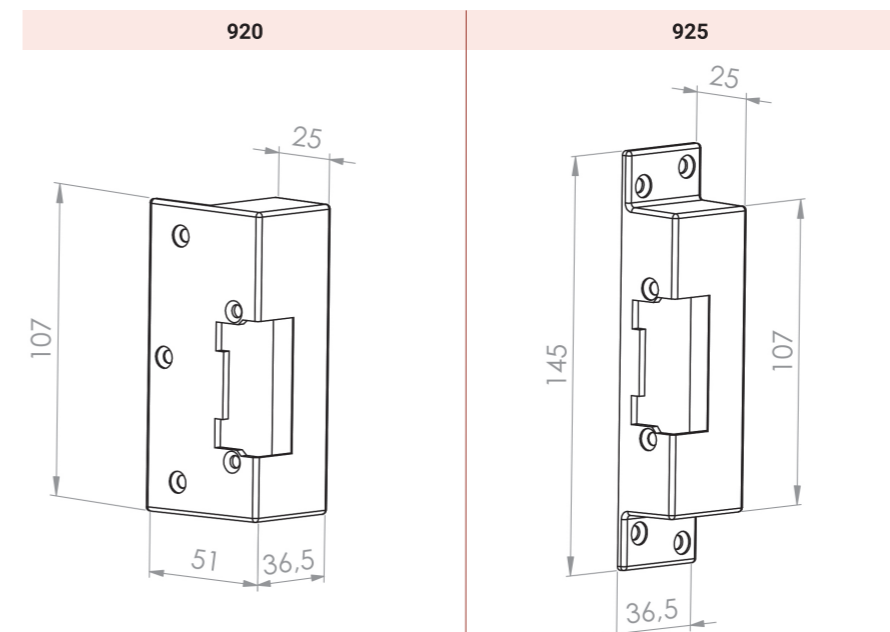

** FRONTALES COMPATIBLES. 901-902 / COMPATIBLE FRONT PLATES. 901-902

Serie **Sobreponer/ RIM**

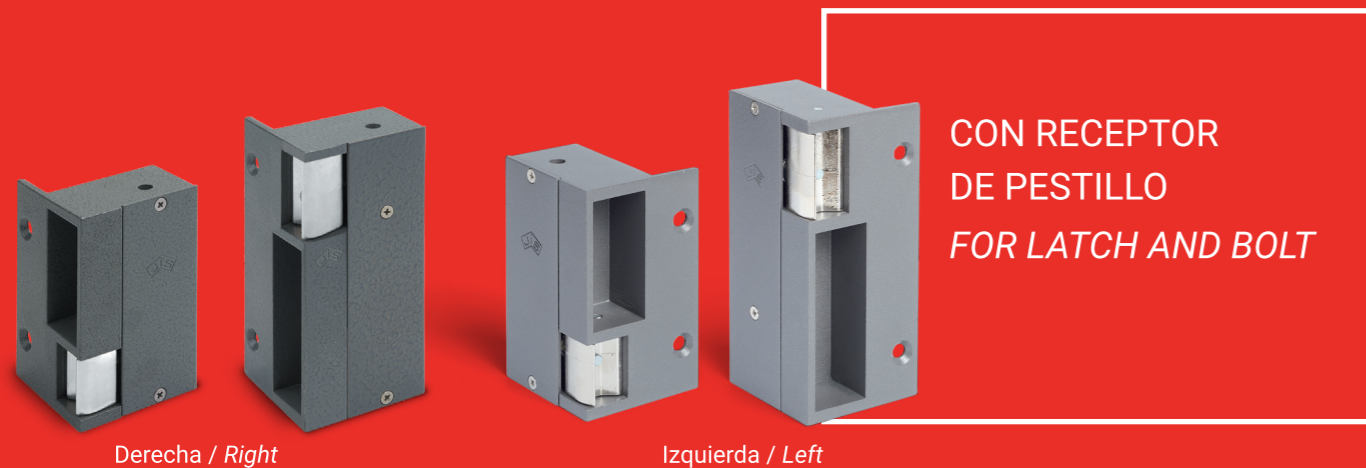

Características técnicas / Technical specifications

	Horizontal	Vertical
Medidas / Dimensions	90 X 50 X 52 mm	120 X 50 X 52
Voltaje / Voltage	Según tabla de bobinas / According to the coils table	
Pestillo ajustable / Adjustable latch	No	
Profundidad de pestillo / Latch bolt depth	5 mm	
Resistencia a la rotura / Break-in resistance	3.000 N	
Precarga / Preload	90 N 12 V AC / 10 N 12 V DC	
Ciclos / Cycles	250.000	
Reversible / Reversible	No	
Posición de instalación / Installation position	Vertical	
Temperatura de trabajo / Operating temperature	-10°C -- + 60°C	
Protección eléctrica / Electrical protection	Opcional (Transil) / Optional (Transil)	

Dimensiones / Dimensions

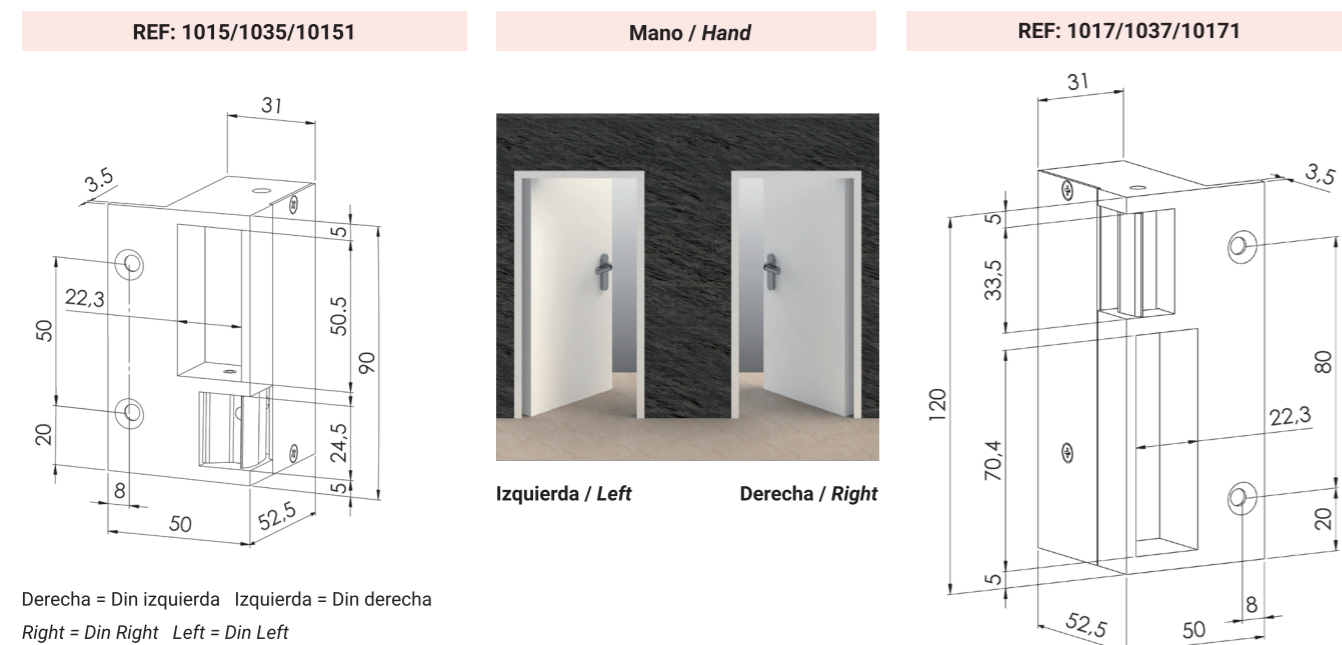

Funciones disponibles / Available features

	Referencia	Estándar	Memoria / Memory	Derecha	Izquierda	Normal	Inverso
	Reference	Standard	Pin	Right	Left	Fail secure	Fail safe
Para cerraduras horizontales For horizontal locks	1015 D	✓		✓		✓	
	1015 I	✓			✓	✓	
	1035 D		✓	✓		✓	
	1035 I		✓		✓	✓	
	10151 D			✓			✓
	10151 I					✓	✓
Para cerraduras verticales For vertical locks	1017 D	✓		✓		✓	
	1017 I	✓			✓	✓	
	1037 D		✓	✓		✓	
	1037 I		✓		✓	✓	
	10171 D			✓			✓
	10171 I					✓	✓

Bobinas disponibles / Available coils

Bobinas / Coils	Normal / Fail secure		Inverso / Fail safe	
	A	B	E	F
Conexión eléctrica / Electrical power	6-12 V AC / DC	12-24 V AC / DC	12 V DC	24 V DC
Trabajo continuo / Continuous duty	100% DC			
	<1'	<1'	12 VDC	24 VDC
Tensión nominal / Nominal voltage V	12 V AC	12 V AC	12 V DC	24 V DC
Resistencia / Resistance Ω	8,5	20	60	150
Consumo / Consumption AC / mA	6 V / 600	12 V / 500		
Consumo / Consumption DC / mA	6 V / 700	12 V / 600	12 V / 250	
Consumo / Consumption AC / mA	12 V / 1200	24 V / 1100		
Consumo / Consumption DC / mA	12 V / 1400	24 V / 1100		24 V / 140
Precarga / Preload AC / N	90	90		
Precarga / Preload DC / N	10	10	10	10
Tolerancia / Range	+/-10%			

Normativas / Norms

Compatibilidad electromagnética / Electromagnetic compatibility	Directiva 2014/ 30 / UE	
RAEE	RII AEE 6783	
Directiva de baja tensión / Low voltage directive	Directiva 2014/ 35 / UE	
Sustancias peligrosas / Hazardous substances	Directiva 2011/ 65 / UE	
Resistencia a la corrosión / Corrosion resistance	UNE-EN-1670	
Herrajes edificación / Building hardware	UNE-EN-14846:2010 / UNE-EN-12209: 2009	
DOP. Clasificación / Classification	Normal / Fail Secure	3 X 2 0 0 L 0 0 0
	Inverso / Fail Safe	3 X 2 0 0 L 0 0 1

Serie Series 1600 Antipanic



REFORZADO / REINFORCED
ALTA SEGURIDAD
HIGH SECURITY
ADAPTABILIDAD
ADAPTABILITY
PARA BARRAS ANTIPÁNICO
FOR PANIC DEVICES

1000 KG

Características técnicas / Technical specifications

Medidas / Dimensions	85 mm X 21,5 mm X 29,5 mm
Medidas con caja 928 / Dimensions with 928 cover box	144 mm X 46 mm X 28 mm
Medidas con caja 938 / Dimensions with 938 cover box	144 mm X 46 mm X 38 mm
Medidas con caja 929 / Dimensions with 929 cover box	155 mm X 45 mm X 35 mm
Voltaje / Voltage	Según tabla de bobinas / According to the coils table
Pestillo ajustable / Adjustable latch	No
Profundidad de pestillo / Latch bolt depth	10,1
Resistencia a la rotura / Break-in resistance	10.000 N
Precarga / Preload	90 N 12 V AC / 10 N 12 V DC
Ciclos / Cycles	250.000
Reversible / Reversible	Simétrico / Symmetric
Posición de instalación / Installation position	Vertical. Horizontal
Temperatura de trabajo / Operating temperature	-10°C + 60°C
Intensidad máxima / Maximum intensity. Microswitch	AC (125 V) - 3A / DC (30 V) - 2A

Suplementos / Spacers

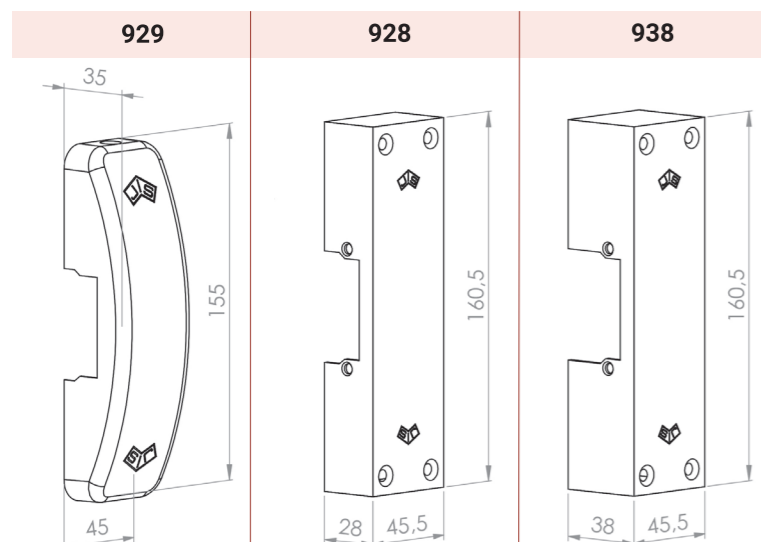

928. 1+2+3+3 mm / For 928 1+2+3+3 mm
 929. 7 unidades de 1 mm / 7 units of 1 mm
 Color. Negro o gris / Colour. Black or grey

Funciones disponibles / Available features

Referencia	Estándar	Memoria interna	Micro	Normal	Inverso
Reference	Standard	Internal memory	Monitored	Fail secure	Fail safe
1610	✓			✓	
1633		✓		✓	
1660			✓	✓	
1663		✓	✓	✓	
1611					✓
1661			✓		✓

*Suplementos / Spacers
 Ref. 07654. Suplemento para 929 / Spacers for 929

Bobinas disponibles / Available coils

Bobinas / Coils	Normal Fail secure				Inverso	Fail safe
	A	B	C	D	E	F
Conexión eléctrica / Electrical power	6-12 V AC / DC	12-24 V AC / DC	12-24 V AC / DC	24-48 V AC / DC	12 V DC	24 V DC
Trabajo continuo / Continuous duty			100% 12 V DC	100% 24 V DC	100% DC	
	<1'	<1'	<1' 12 V AC <1' 24 V AC / DC	<1' 24 V AC <1' 48 V AC / DC	12 VDC	24 VDC
Tensión nominal / Nominal voltage V	12 V AC	12 V AC	12 V AC	24 V AC	12 V DC	24 V DC
Resistencia / Resistance Ω	8,5	20	40	150	60	150
Consumo / Consumption AC / mA	6 V / 600	12 V / 500	12 V / 250	24 V / 150		
Consumo / Consumption DC / mA	6 V / 700	12 V / 600	12 V / 300	24 V / 170	12 V / 300	
Consumo / Consumption AC / mA	12 V / 1200	24 V / 1100	24 V / 510	48 V / 300		
Consumo / Consumption DC / mA	12 V / 1400	24 V / 1100	24 V / 600	48 V / 340		24 V / 170
Precarga / Preload AC / N	90	90	90	90		
Precarga / Preload DC / N	10	10	10	10	10	10
Tolerancia / Range	+/-10%					

Normativas / Norms

Compatibilidad electromagnética / Electromagnetic compatibility	Directiva 2014/ 30 / UE	
RAEE	RII AEE 6783	
Directiva de baja tensión / Low voltage directive	Directiva 2014/ 35 / UE	
Sustancias peligrosas / Hazardous substances	Directiva 2011/ 65 / UE	
Resistencia a la corrosión / Corrosion resistance	UNE-EN-1670	
Herrajes edificación / Building hardware	UNE-EN-14846:2010 / UNE-EN-12209: 2009	
DOP. Clasificación / Classification	Normal / Fail Secure	3 X 3 0 0 L 0 0 0
	Inverso / Fail Safe	3 X 3 0 0 L 0 0 1

Serie Series 1700 Antipanic



VERSABILIDAD / VERSABILITY

ADAPTABILIDAD
ADAPTABILITY

PARA BARRAS ANTIPÁNICO
FOR PANIC DEVICES

Características técnicas / Technical specifications

Medidas / Dimensions	67 mm X 20,5 mm X 28,5 mm
Medidas con caja 928 / Dimensions with 928 cover box	144 mm X 46 mm X 28 mm
Medidas con caja 938 / Dimensions with 938 cover box	144 mm X 46 mm X 38 mm
Medidas con caja 929 / Dimensions with 929 cover box	155 mm X 45 mm X 35 mm
Voltaje / Voltage	Según tabla de bobinas / According to the coils table
Pestillo ajustable / Adjustable latch	No
Profundidad de pestillo / Latch bolt depth	10,1
Resistencia a la rotura / Break-in resistance	4.000 N
Precarga / Preload	90 N 12 V AC / 10 N 12 V DC
Ciclos / Cycles	250.000
Reversible / Reversible	Simétrico / Symmetric
Posición de instalación / Installation position	Vertical. Horizontal
Temperatura de trabajo / Operating temperature	-10°C + 60°C
Protección eléctrica / Electrical protection	Opcional (Transil) / Optional (Transil)
Intensidad máxima / Maximum intensity. Microswitch	AC (125 V) - 3A / DC (30 V) - 2A

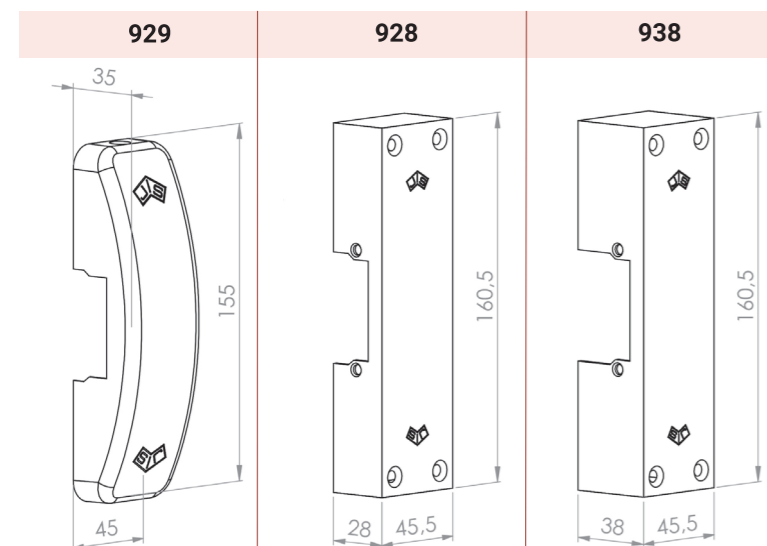

Suplementos / Spacers



928. 1+2+3+3 mm / For 928 1+2+3+3 mm
929. 7 unidades de 1 mm / 7 units of 1 mm
Color. Negro o gris / Colour. Black or grey

Funciones disponibles / Available features

Referencia	Estándar	Palanca desbloqueo	Memoria interna	Micro	Normal	Inverso
Reference	Standard	Releasing lever	Internal Memory	Monitored	Fail secure	Fail safe
1770	✓				✓	
1772	✓	✓			✓	
1773			✓		✓	
1774		✓	✓		✓	
1790	✓			✓	✓	
1771						✓
1791				✓		✓

*Consultar otras opciones con señal / Ask for other options with signal

*Suplementos / Spacers

Ref. 07654. Suplemento para 929 / Spacers for 929

Bobinas disponibles / Available coils

Bobinas / Coils	Normal / Fail secure				Inverso / Fail safe	
	A	B	C	D	E	F
Conexión eléctrica / Electrical power	6-12 V AC/DC	12-24 V AC/DC	12-24 V AC/DC	24-48 V AC/DC	12 V DC	24 V DC
Trabajo continuo / Continuous duty			100% 12V DC	100% 24V DC	100% DC	
	<1'	<1'	<1' 12 V AC <1' 24 V AC / DC	<1' 24 V AC <1' 48 V AC / DC	12 V DC	24 V DC
Tensión nominal / Nominal voltage V	12 V AC	12 V AC	12 V AC	24V AC	12 V DC	24 V DC
Resistencia / Resistance Ω	8,5	20	40	150	60	150
Consumo / Consumption AC / mA	6 V / 600	12 V / 500	12 V / 250	24 V / 150		
Consumo / Consumption DC / mA	6 V / 700	12 V / 600	12 V / 300	24 V / 170	12 V / 200	24 V / 160
Consumo / Consumption AC / mA	12 V / 1200	24 V / 1100	24 V / 510	48 V / 300		
Consumo / Consumption DC / mA	12 V / 1400	24 V / 1100	24 V / 600	48 V / 340		
Precarga / Preload AC / N	90	90	90	90		
Precarga / Preload DC / N	10	10	10	10	10	10
Tolerancia / Range	+/-10%					

*Opción bobina V bitensión 12 ó 24 VDC. Ver página 17

*Optional coil V bitension 12 or 24 VDC. See page 17

Normativas / Norms

Compatibilidad electromagnética / Electromagnetic compatibility	Directiva 2014/ 30 / UE
RAEE	RII AEE 6783
Directiva de baja tensión / Low voltage directive	Directiva 2014/ 35 / UE
Sustancias peligrosas / Hazardous substances	Directiva 2011/ 65 / UE
Resistencia a la corrosión / Corrosion resistance	UNE-EN-1670
Herrajes edificación / Building hardware	UNE-EN-14846:2010 / UNE-EN-12209: 2009
DOP. Clasificación / Classification	Normal / Fail Secure Inverso / Fail Safe

3	X	2	0	0	L	0	0	0	0
3	X	2	0	0	L	0	0	0	1

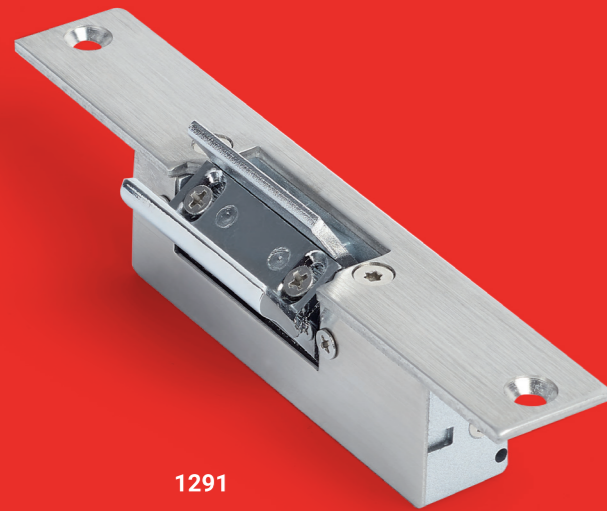

1291

PARA PUERTAS DE VIDRIO
BATIENTES
ACTÚA DIRECTAMENTE
SOBRE LA HOJA DE VIDRIO

FOR SWING GLASS DOORS
WORKS DIRECTLY ON THE
GLASS LEAF

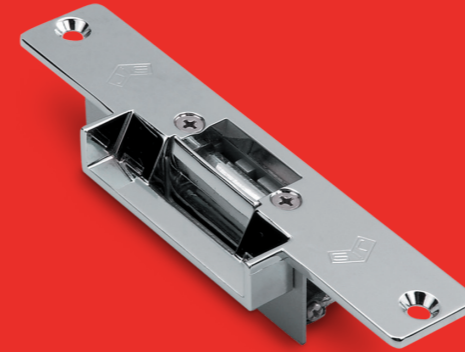

1210

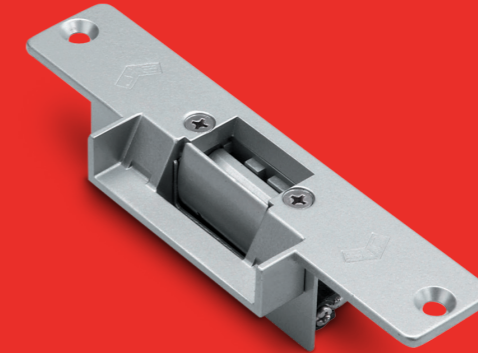

1211



1250

Características técnicas / Technical specifications

Medidas / Dimensions	160 X 25 X 28
Voltaje / Voltage	12 V DC
Espesor vidrio / Glass thickness	12-15 mm
Profundidad de pestillo / Latch bolt depth	11,8 mm
Resistencia a la rotura / Break-in resistance	5.000 N
Precarga / Preload	10 N 12 V DC
Ciclos / Cycles	250.000
Reversible / Reversible	SI / YES
Posición de instalación / Installation position	Vertical. Horizontal
Temperatura de trabajo / Operating temperature	-10°C -- + 60°C
Protección eléctrica / Electrical protection	Si / Yes

Funciones disponibles / Available features

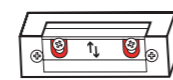

Referencia	Pestillo ajustable	Inverso
Reference	Adjustable latch	Fail safe
1291	✓	✓

Bobinas disponibles / Available coils

Bobinas / Coils	Inverso / Fail safe
E	
Conexión eléctrica / Electrical power	12 V DC
Tensión nominal / Nominal voltage V	12 V DC
Resistencia / Resistance Ω	42
Consumo / Consumption 12 DC	200 mA
Tolerancia / Range	+/-10%

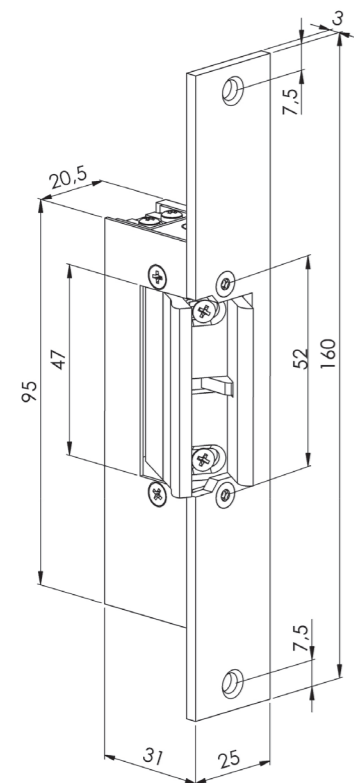

Características técnicas / Technical specifications

	1210 - 1211	1250
Medidas / Dimensions	150 X 39,5 X 36,5 mm	124 X 32 X 32,5 mm
Voltaje / Voltage	12 V DC	12-24 AC / DC
Pestillo ajustable / Adjustable latch	No	No
Profundidad de pestillo / Latch bolt depth	13,5 mm	11 mm
Picaporte / Door latch	5/8" (15,8 mm)	1/2" (12,7 mm)
Resistencia a la rotura / Break-in resistance	3.000 N	3.000 N
Precarga / Preload	90 N 12 V AC / 10 N 12 V DC	90 N 12 V AC / 10 N 12 V DC
Ciclos / Cycles	250.000	250.000
Reversible / Reversible	Simétrico / Symmetric	Simétrico / Symmetric
Posición de instalación / Installation position	Vertical. Horizontal.	Vertical. Horizontal.
Temperatura de trabajo / Operating temperature	-10°C -- + 60°C	-10°C -- + 60°C
Protección eléctrica / Electrical protection	NO	Diode

Funciones disponibles / Available features

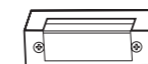

Referencia	Estándar	Normal	Inverso
Reference	Standard	Fail secure	Fail safe
1210	✓	✓	
1211	✓		✓
1250	✓	✓	✓

Bobinas disponibles / Available coils

Bobinas / Coils	Normal Fail Secure	Inverso Fail Safe
1210 - 1211		
Conexión eléctrica / Electrical power	12 V DC	
Tensión nominal / Nominal voltage V	12 V DC	
Resistencia / Resistance Ω	42	
Consumo / Consumption 12 DC	140 mA	
Consumo / Consumption 24 DC	140 mA	
Tolerancia / Range	+/- 10%	
1250		
Normal - inverso / Fail secure- Fail safe	Seleccionable / Changeable	
Conexión eléctrica / Electrical power	12 - 24 V DC	
Tensión nominal / Nominal voltage V	12 - 24 V DC	
Resistencia / Resistance Ω	42	
Consumo / Consumption 12 DC	140 mA	
Consumo / Consumption 24 DC	280 mA	
Tolerancia / Range	+/- 10%	

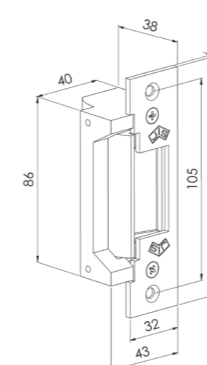
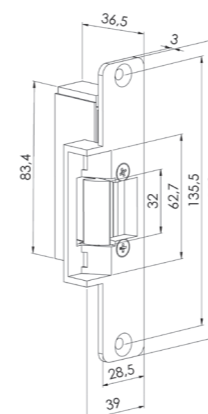

Acabados / Finisings
G = Gris / Grey CR = Cromado / Chrome
*Frontal inoxidable / Stainless steel front plate

Frontales / Front Plates

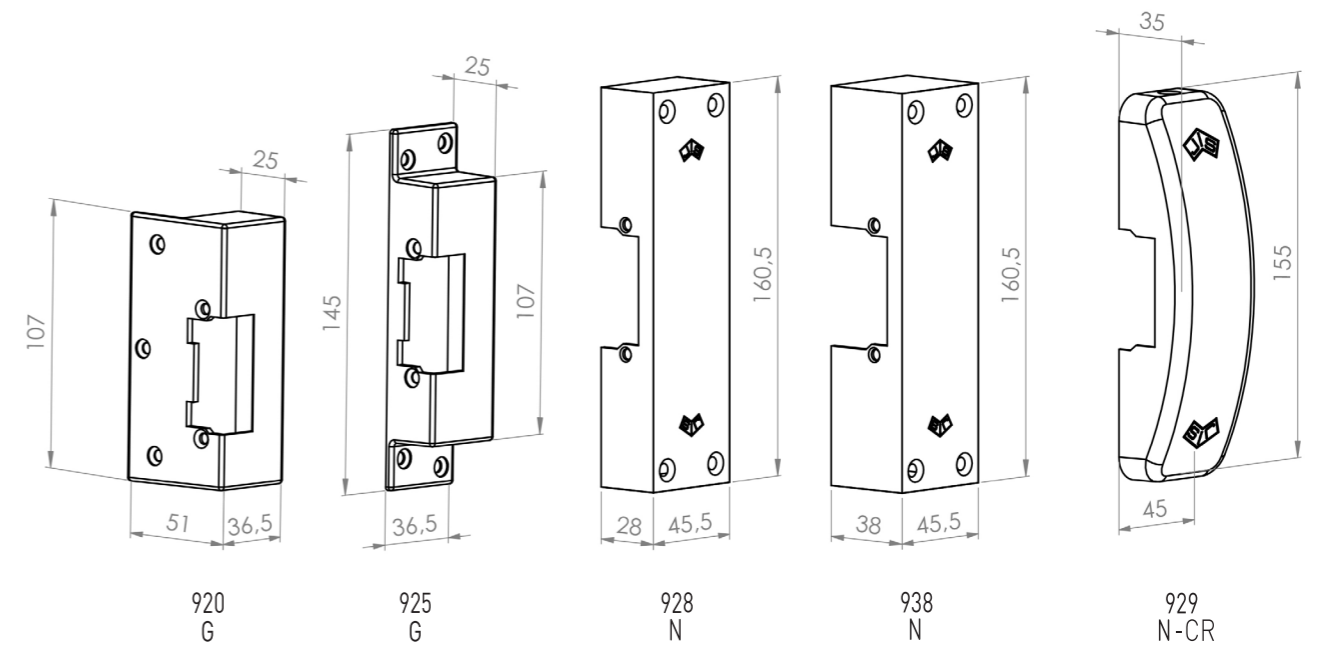
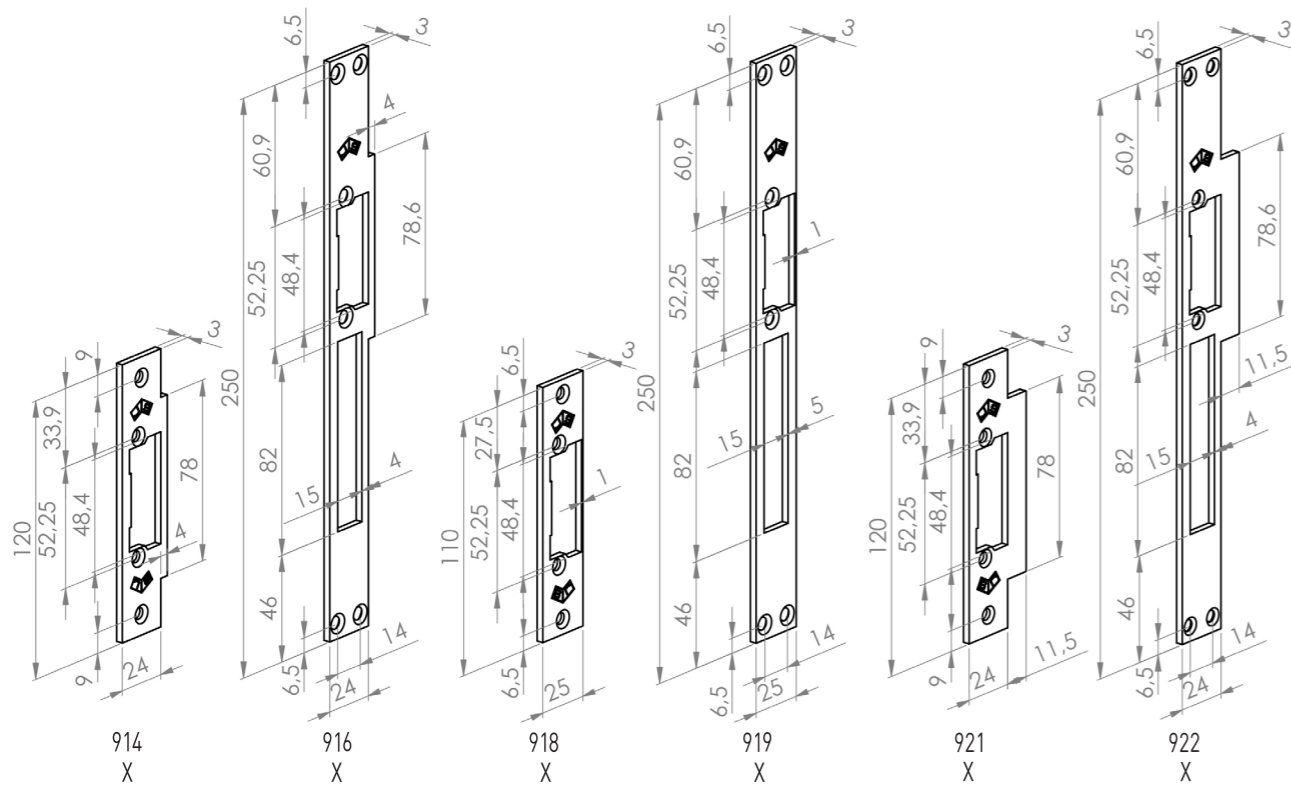
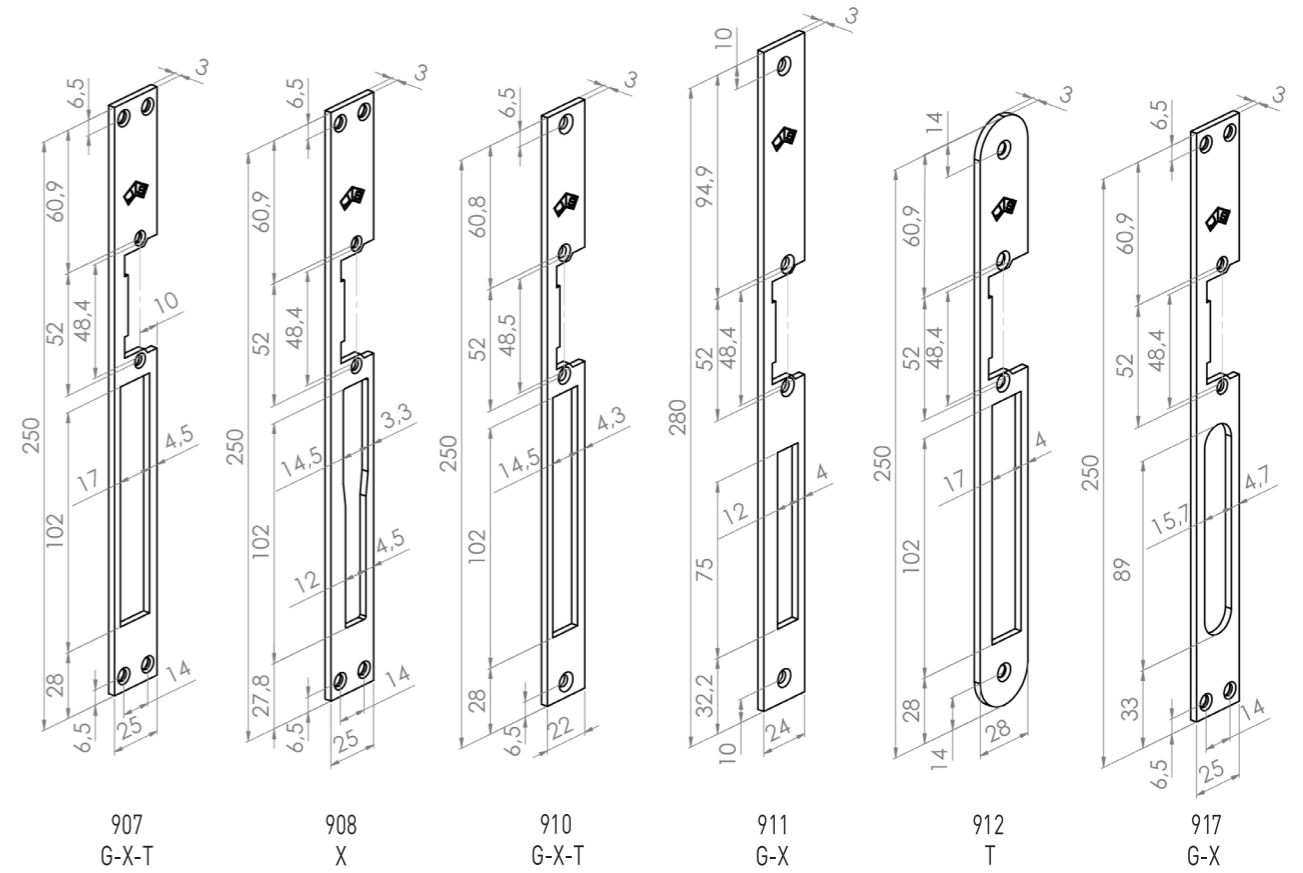
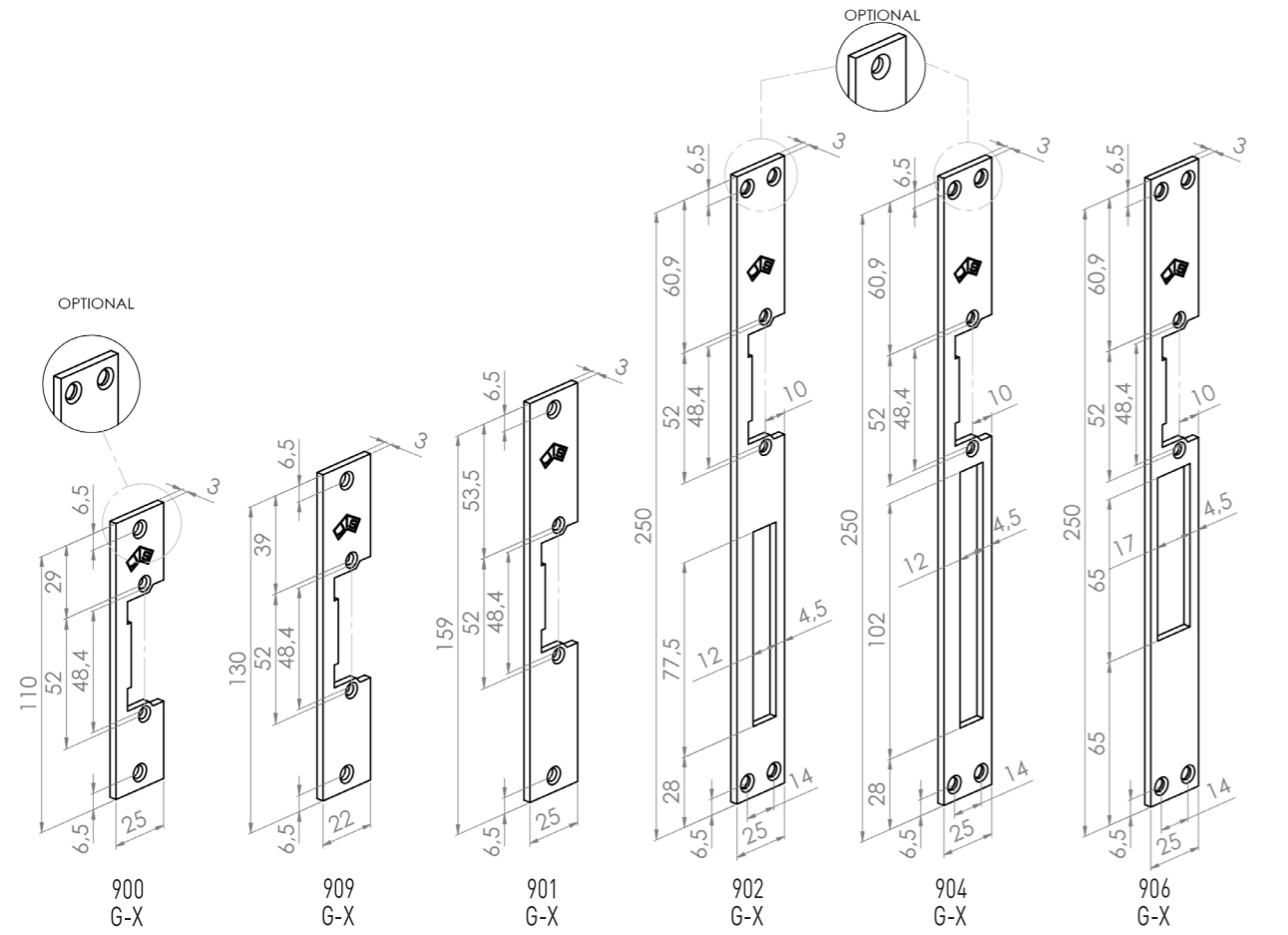

Frontales / Front Plates

➤ No reversible / Non reversible

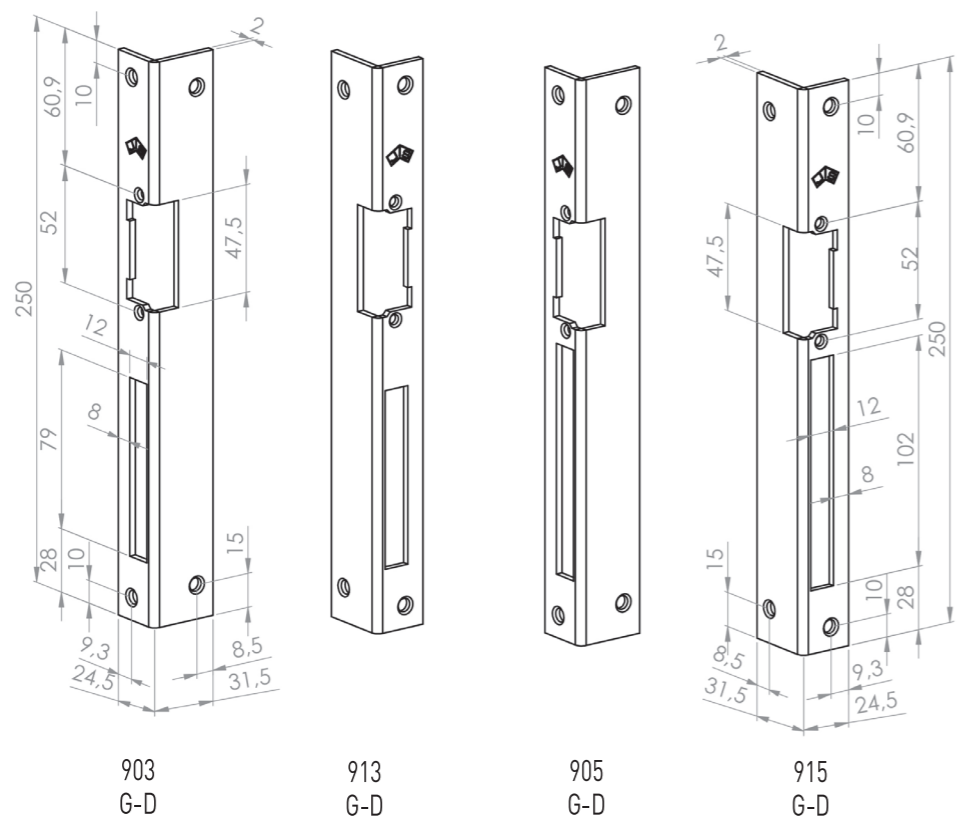

➤ No reversible / Non reversible

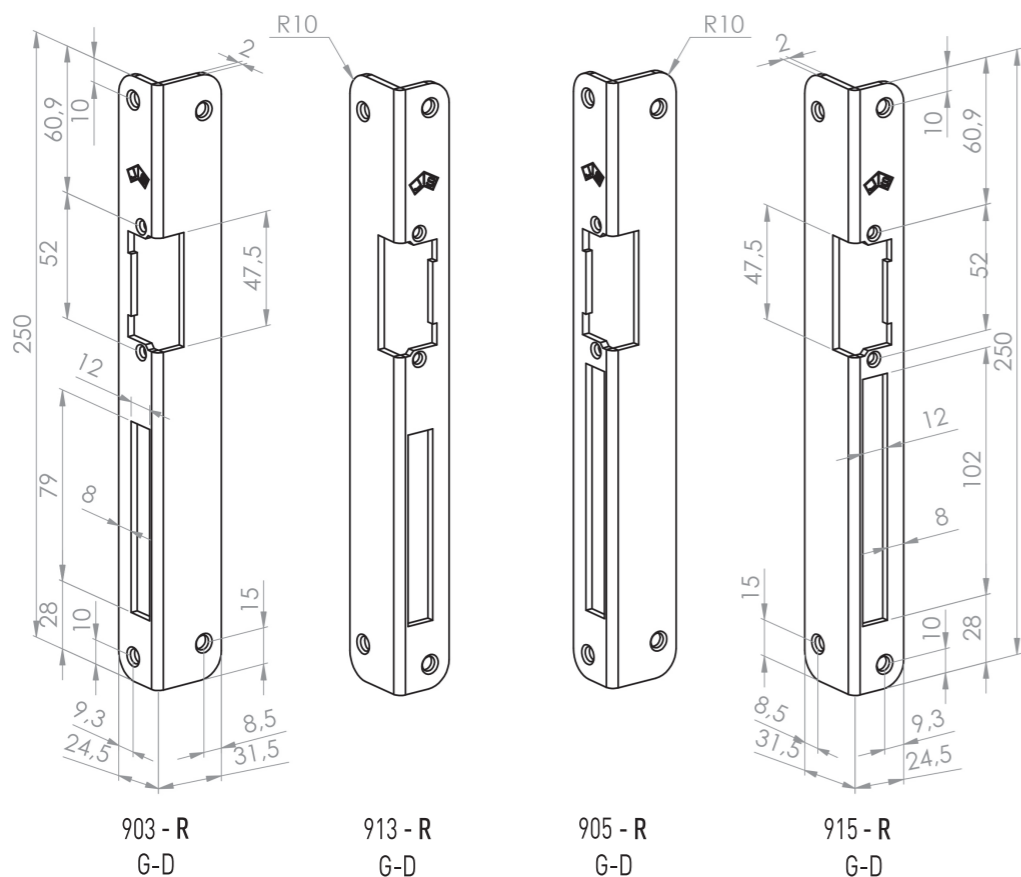

Frontales recomendados / Suggested front plates

Referencia	Modelos								
Reference	Series								
Cod / Code	800	1400	1400 RF	1400 RFT	1500	1600 Antipanic	1700	1700 Antipanic	Color / Finish
900					✓		✓		G - X
901	✓				✓		✓		G - X
902	✓				✓		✓		G - X
903	✓						✓		G - D
904							✓		G - X
905							✓		G - D
906							✓		G - X
907							✓		G - X - T
908							✓		X
909		✓	✓						G - X
910		✓	✓						G - X
911	✓						✓		G - X
912							✓		T
913	✓				✓		✓		G - D
914				✓					X
915							✓		G - D
916				✓					X
917							✓		G - X
918				✓					X
919				✓					X
920	✓						✓		G
921				✓					X
922				✓					X
925	✓						✓		G
928						✓		✓	N
929						✓		✓	N - CR
938						✓		✓	N

- D Dorado / Gold
- G Acero Gris / Grey Steel
- X Acero Inoxidable / Stainless Steel
- N Negro / Black
- CR Cromado aspecto inox brochado / Chromo finishing stainless steel brooch
- T Latón / Brass

Nota / Remark
* Medidas y opciones especiales consultar / Ask for special mesures

 Espesor frontales 3 mm / Front plate thickness 3 mm
Ángulo 2 mm / Angle 2 mm



Twin lock

TWIN LOCK



SEGURIDAD / SECURITY
ANTIPÁNICO / ANTIPANIC
SILENCIOSO / SILENT



Electro Cerradura / Electric Lock

Indicado para garajes, porterías, empresas, colegios, comunidades y edificios con control de accesos.
For garages, buildings entrances, companies, schools, communities and buildings with access control.

Características técnicas / Technical specifications

Medidas / Dimensions	Según referencia / As per reference
Distancia entre ejes / Distance between axes	85 mm 72 mm en opción / On request
Voltaje / Voltage	12 V AC / DC
Consumo / Consumption mA 12 V AC	820 mA
Consumo / Consumption mA 12 V DC	1.120 mA
Ciclos / Cycles	200.000
Reversible / Reversible	Si / Yes
Posición de instalación / Installation position	Vertical
Temperatura de trabajo / Operating temperature	-10°C + 60°C
Protección eléctrica / Electrical protection	Si / Yes (Fusible térmico / Thermal fuse)
Señal estado puerta / Signal door status	Opcional / Optional
Señal sonora de apertura / Opening sound signal	Opcional / Optional. Zumbador-Buzzer

- SEGURIDAD, PESTILLO SIEMPRE PASADO. BLOQUEO AUTOMÁTICO
SECURITY, BOLT ALWAYS LOCKED. SELF LOCKING LOCK
- Fácil instalación. Parte eléctrica en el marco.
Easy to install. Electrical part in the frame.
- Sistema compuesto de cerradura mecánica y cerradero eléctrico.
System composed of mechanical lock and electric strike.
- Apertura eléctrica, o manual mediante cilindro o manecilla.
Electric or manual opening by cylinder or handle.
- Antipánico, la cerradura siempre se puede abrir desde el interior.
Antipanic, the lock can always be opened from the inside.
- Sistema protegido contra la intrusión. Anti tarjeta.
Intrusion protected system. Anti card.
- Estanco. Certificado para ambiente salino Grado 3.
Water tight. Certified for saline environment. Grade 3.
- Certificado para salidas de emergencia según norma EN 179.
Certified for emergency exits according to EN 179 standard.
- Alojamiento de pestillo ajustable.
Bolt housing adjustable.

Parte eléctrica / Electric part

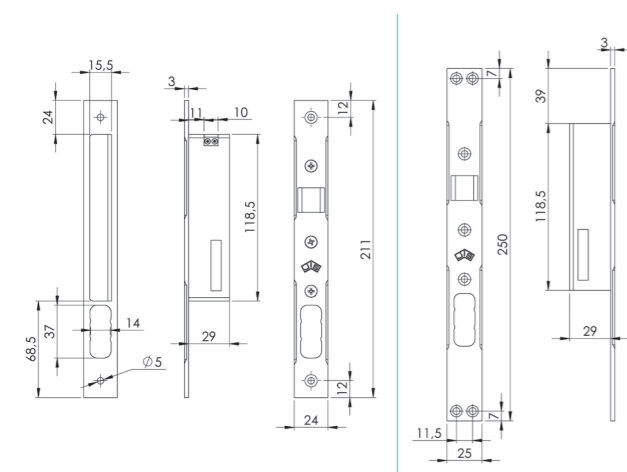

Parte mecánica / Mechanical part

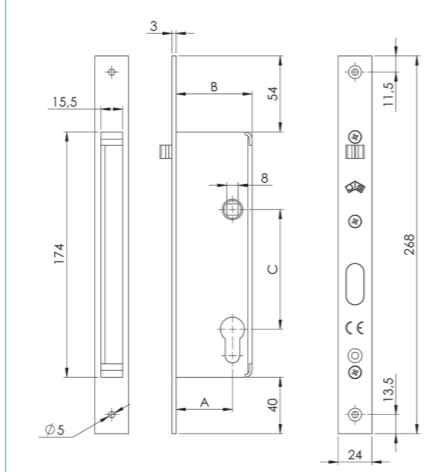

Montaje / Installation

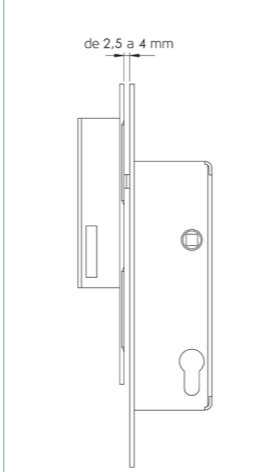

Antipánico / Antipanic

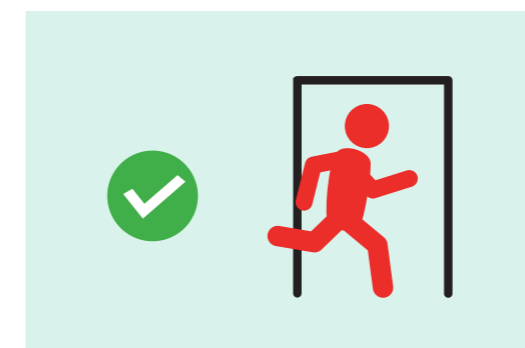

Anti tarjeta / Anti card

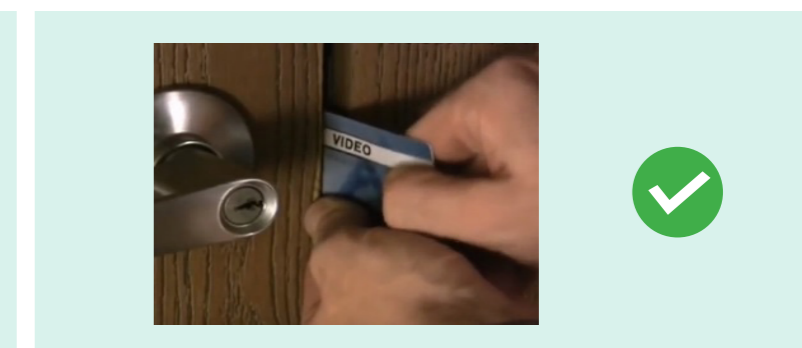

Normativa / Norm EN179
3 6 5 0 1 3 2 1 A B/D

TWIN LOCK

Referencias disponibles / Available references

Distancia entre ejes / Distance between axes 85 mm				
	Referencia Reference	Aguja Backset (A)	Caja Case depth (B)	Entre ejes Interaxes (C)
TWIN LOCK	1320	20	34	85
TWIN LOCK	1325	25	39	85
TWIN LOCK	1330	30	44	85
TWIN LOCK	1335	35	49	85
TWIN LOCK	1340	40	54	85
TWIN LOCK	1350	50	61	85
TWIN LOCK	1360	60	71	85

Distancia entre ejes / Distance between axes 72 mm				
	Referencia Reference	Aguja Backset (A)	Caja Case depth (B)	Entre ejes Interaxes (C)
TWIN LOCK	1337	35	49	72
TWIN LOCK	1342	40	54	72
TWIN LOCK	1352	50	61	72
TWIN LOCK	1362	60	71	72

Mecanismos eléctricos / Electrical parts		
CIERRE/STRIKE	1300	Parte eléctrica / Electrical part 211 mm
CIERRE/STRIKE 24h	1302	24 Horas / 24 Hours. 100% DC
CIERRE/STRIKE	1305	Parte eléctrica / Electrical part 250 mm.

* Frontal de 250 mm, añadir una L a la referencia. p.e. 1320 L
 * Front plate 250 mm, add a L to the reference. p.e. 1320 L
 * Opcional canto redondo / Round edge optional



Distancia separación entre partes 2,5 a 4 mm / Distance separation between parts 2,5 a 4 mm

El cilindro admite leva larga o corta / Short or long cam cylinder

MOTORIZADA MOTORIZED



- PARA CONTROL DE ACCESO
FOR ACCES CONTROL
- Apertura limitada a 3-4 segundos, tras el impulso eléctrico.
Opening limited to 3-4 seconds, after electrical impulse.
- Cierre motorizado para apertura de todo tipo de cerraduras.
Motorized strike for opening all types of locks.
- El impulso eléctrico actúa sobre el pestillo.
The electric impulse moves the bolt.
- Posición de instalación: vertical y horizontal.
Installation position: vertical and horizontal.
- Voltaje 12 V DC / 24 V DC opcional.
Voltage 12 V DC / 24 V DC optional.
- Consumo / Consumption 12 V DC 500 mA.
- Función puerta batiente / Free pass function.

Referencias disponibles / Available references

Distancia entre ejes / Distance between axes 85 mm				
	Referencia Reference	Aguja Backset (A)	Caja Case depth (B)	Entre ejes Interaxes (C)
TWIN LOCK	1320 SB	20	34	85
TWIN LOCK	1325 SB	25	39	85
TWIN LOCK	1330 SB	30	44	85
TWIN LOCK	1335 SB	35	49	85
TWIN LOCK	1340 SB	40	54	85
TWIN LOCK	1350 SB	50	61	85
TWIN LOCK	1360 SB	60	71	85
CIERRE/STRIKE	1306	Parte eléctrica / Electrical part 268 mm.		

* Señal estado de puerta / Door status signal. Opcional / In option.
 * Señal sonora de apertura / Opening door sound. Opcional / In option.

Parte mecánica / Mechanical part

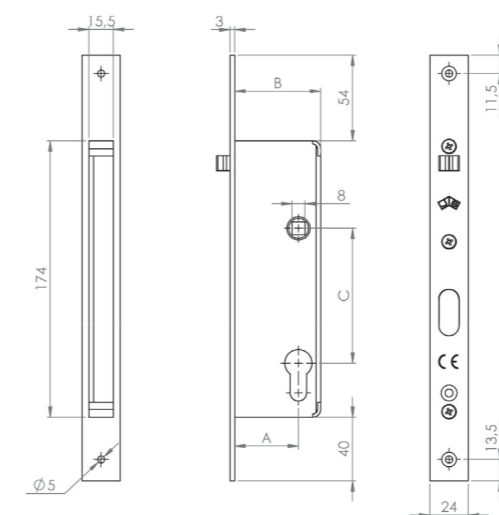

Parte eléctrica / Electrical part

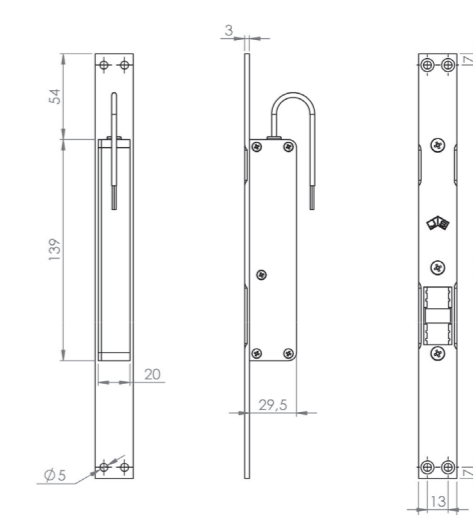



Cerraduras eléctricas
Electric locks



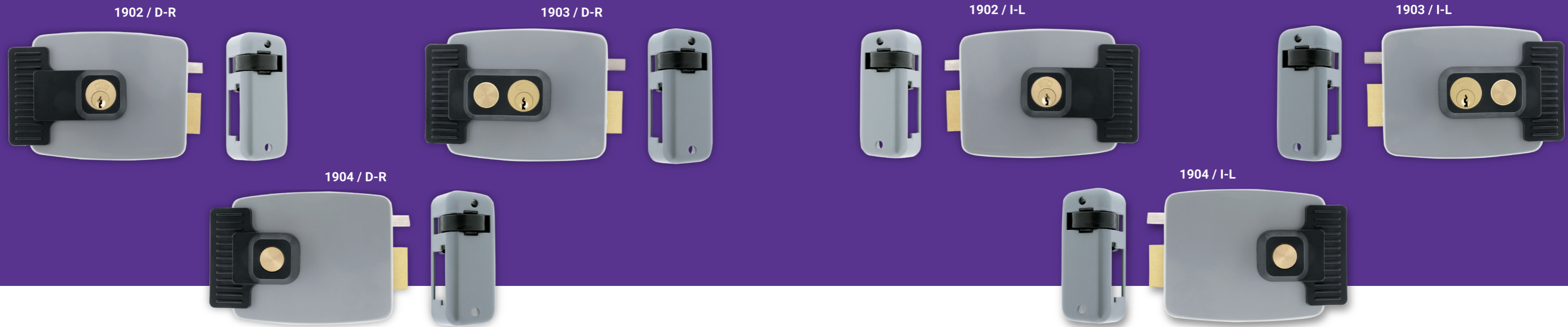

Características técnicas / Technical specifications

Medidas / Dimensions	102,9 X 125,35 X 34,5
Voltaje / Voltage	12 V AC
Consumo / Consumption	3 A
Pestillo ajustable / Adjustable latch	No
Reversible / Reversible	No
Posición de instalación / Installation position	Horizontal.
Longitud de cilindro / Cylinder length	De 50 a 80 mm / From 50 to 80 mm
Protector metálico / Metallic cover	Si / Yes

Medidas / Dimensions

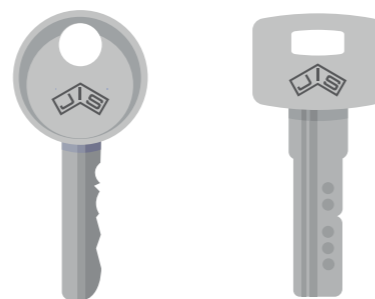
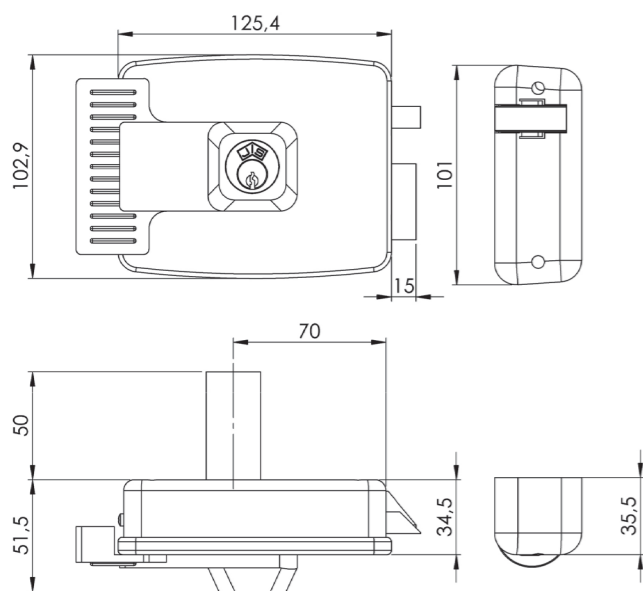

1902	1912
1903	1913
1904	

Funciones disponibles / Available features

Referencia	Cilindro	Pulsador	Llave serreta	Llave seguridad	Derecha*	Izquierda*
Reference	Cylinder	Button	Standard key	Security key	Rigth*	Left*
1902 D	✓		✓		✓	
1902 I	✓		✓			✓
1903 D	✓	✓	✓		✓	
1903 I	✓	✓	✓			✓
1904 D	✓	✓	✓		✓	
1904 I	✓	✓	✓			✓
1912 D	✓			✓	✓	
1912 I	✓			✓		✓
1913 D	✓	✓		✓	✓	
1913 I	✓	✓		✓		✓

Forma tradicional / Traditional way



Izquierda / Left Derecha / Right Derecha / Right Izquierda / Left

Norma din / Din norm



Derecha / Right Izquierda / Left Izquierda / Left Derecha / Right

Ref: P1900. Accesorio prolongador / Enlargement accessory, hasta / up to 100 mm.
Ref: 07338 Bobina de recambio derecha / Replacement coil right
Ref: 07339 Bobina de recambio izquierda / Replacement coil left
Cilindro de recambio / Replacement cylinder

*Derecha = Din izquierda Izquierda = Din derecha

*Right = Din right Left = Din left

1960



1961



1970



1971



Características técnicas / Technical specifications

	1960	1961
Medidas / Dimensions	230 X 25 X 43 mm	210 X 25 X 43 mm
Pistón / Bolt ø	14 mm	14 mm
Posición de instalación / Installation position	Embutir / Mortise	Embutir / Mortise
Voltaje / Voltage	12 / 24 V DC	12 / 24 V DC
Función / Feature	Standard	Inverso / Fail safe
Consumo / Consumption 12 V DC. Reposo - Activo / Standby - Active	200 / 800 mA	200 / 800 mA
Consumo / Consumption 24 V DC. Reposo - Activo / Standby - Active	100 / 500 mA	100 / 500 mA
Sensor puerta / Door sensor	Si / Yes	Si / Yes
Temporizador ajustable / Adjustable timer	0,3,6,9 s	0,3,6,9 s
Admite cilindro / Cylinder facility	Si / Yes	No

Características técnicas / Technical specifications

	1970	1971
Medidas / Dimensions	215 X 22 X 40 mm	150 X 22 X 40 mm
Pistón / Bolt ø	12 mm	12 mm
Posición de instalación / Installation position	Embutir / Mortise	Embutir / Mortise
Voltaje / Voltage	12 / 24 V DC	12 V DC
Función / Feature	Standard	Inverso / Fail safe
Consumo / Consumption 12 V DC. Reposo - Activo / Standby - Active	200 / 800 mA	200 / 800 mA
Consumo / Consumption 24 V DC. Reposo - Activo / Standby - Active	100 / 500 mA	
Sensor puerta / Door sensor	Si / Yes	Si / Yes
Temporizador ajustable / Adjustable timer	0,3,6,9 s	No
Admite cilindro / Cylinder facility	Si / Yes	No

1960

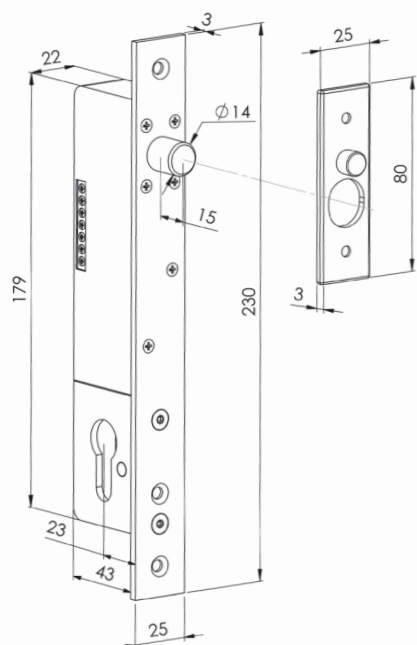

1961

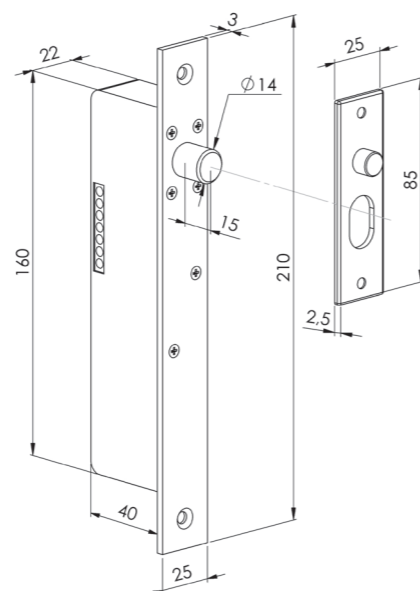

1970

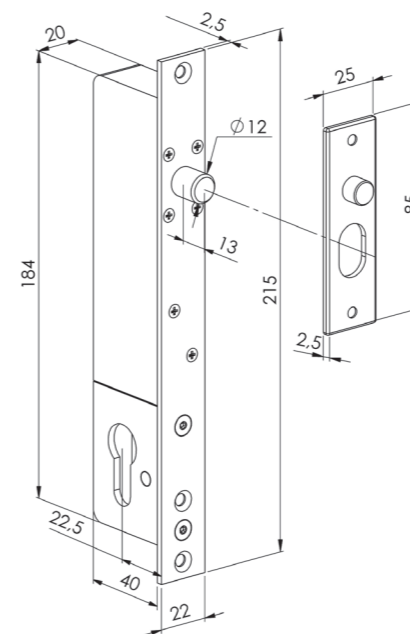

1971

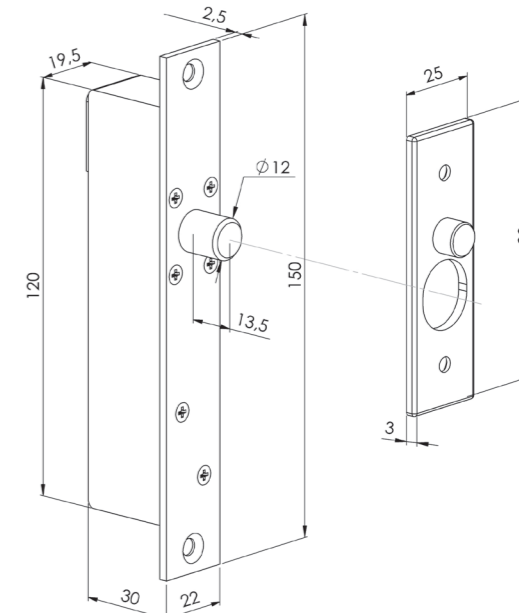



Sistemas de apertura
Opening systems

TECLADO NUMÉRICO - TARJETA KEYPAD - CARD

6501

6502

6503



CONTROL DE ACCESO
AUTÓNOMO / STANDALONE
ACCES CONTROL

ADMITE HASTA 2.000
USUARIOS / UP TO 2.000
USERS

LECTOR HUELLA DACTILAR - TARJETA FINGERPRINT READER - CARD

6602



CONTROL DE ACCESO
AUTÓNOMO / STANDALONE
ACCES CONTROL

FÁCIL LECTURA DE LA
HUELLA DIGITAL / EASY
FINGERPRINT READING

Características generales / General features

	6501	6502	6503
Medidas / Dimensions	135 X 58 X 26 mm	128 X 82 X 28 mm	158 X 43 X 22 mm
Número de accesos / Door relays	1	2	1
Capacidad de usuarios / Users capacity	2.000	1.100 + 100	2.000
Teclado Iluminado / Illuminated keypad		Si / Yes	
Anti vandálico / Anti vandalism		Si / Yes	
Tipo de frecuencia / Frequency type		EM 125 Khz	
Interface de comunicación / Communication interface		Wiegand 26-37	
Longitud de códigos / Password length		4 a / to 8	
Modo de acceso / Access mode	Tarjeta / llavero / Card / Clamshell tag		
	Código / Pin		
	Tarjeta / llavero + Código / Card / Clamshell tag + Pin		
Timbre de puerta / Door bell	No	No	Si
Voltaje / Voltage	12 - 18 V AC / 12 -24 DC		12 - 24 DC
Consumo / Consumption	≤35 mA		
Protección exterior / Outside protection	IP 68	IP 68	IP 65
Ajuste tiempo de apertura / Adjustable door relay	0 a / To 99 s		
Temperatura de trabajo / Operating temperature	-40 °C - 60°C		

Referencias / References

- **6501 / 6503 KIT** Teclado / Keypad
6501. Transformador / Transformer ref 6900 220 V a/to 12 V AC.
6503. Fuente de alimentación / Power supply ref 6902 220 V to 12 V DC.
Cierre eléctrico / Electric door opener. 1720 901 X / A para / for 6501. 1720 901 X / B para / for 6501
2 Tarjetas master (adición + eliminación) / 2 manager cards (add + delete)
1 Tarjeta de usuario / 1 user card
Diodo de protección / Protection diode
- **6502 KIT** Teclado / Keypad
6502. Transformador / Transformer ref 6900 220 V a/to 12 V AC.
Cierre eléctrico / Electric door opener. 1720 901 X / A
1 Tarjeta de usuario / 1 user card
Diodo de protección / Protection diode
- **T 6501 / T6502 / T 6503** Unidad de teclado / Keypad unit

Características generales / General features

	6602
Medidas / Dimensions	115 X 70 X 33 mm
Número de accesos / Door relays	1
Capacidad de usuarios / User code capability	Tarjeta / card (1.000) Huella / Fingerprint (2.000)
Teclado Iluminado / Illuminated keypad	Si / Yes
Anti vandálico / Anti vandalisim	Si / Yes
Tipo de frecuencia / Frequency type	EM 125 Khz
Interface de comunicación / Communication interface	Wiegand 26
Modo de acceso / Access mode	Tarjeta / Card Huella / Fingerprint
Voltaje / Voltage	DC 12 V ± 10%
Consumo / Consumption	Descanso / Standby ≤20mA En uso / In use ≤80mA
Protección exterior / Outside protection	IP 68
Ajuste tiempo de apertura / Adjustable door relay time	0 a / To 99 s
Temperatura de trabajo / Operating temperature	-40 °C - 60°C

Referencias / References

- **6602 KIT** Lector de huella y tarjeta / Fingerprint
Fuente de Alimentación / Power supply ref 6902 220 V a/to 12 V DC
Cierre eléctrico / Electric door opener. 1720 901 X / B
2 Tarjetas master (adición + eliminación) / 2 manager cards (add + delete)
1 Tarjeta de usuario / 1 user card
Mando a distancia para programar / Remote control for programming
- **T 6602** Unidad de lectura de huellas / Fingerprint reading unit

CONTROL REMOTO REMOTE CONTROL



RECEPTOR
RECEIVER 433 MHZ

APERTURA A DISTANCIA
REMOTE OPENING

ADMITE HASTA 126 USUARIOS
UP TO 126 USERS

Características generales / General features

	6700
Medidas / Dimensions	127 X 70 X 52 mm
Número de accesos / Door relays	1
Capacidad de usuarios / User capacity	500
Tipo de frecuencia / Frequency type	433,92 Khz
Modo de acceso / Access mode	Mando a distancia / Remote control
Voltaje / Voltage	12 / 24 V AC / DC
Protección exterior / Outside protection	IP 44
Temperatura de trabajo / Operating temperature	-20 °C - 85 °C
Alcance / Range	100 m
Tipo de códigos / Type codes	Códigos dinámicos / Dynamic codes

Referencias / References

➤ **6700 KIT** Emisor-mando 1 canal / Transmitter-command 1 channel
Cierre eléctrico / Electrical door opener. 1720 901 X / A
Transformador / Transformer ref 6900 220 V a/to 12 V AC
Receptor / Receiver

➤ **6710** Mando a distancia / Remote control



LECTOR DE TARJETA CARD READER



LECTOR AUTÓNOMO
STANDALONE CARD READER

ADMITE HASTA
10.000 USUARIOS
UP TO 10.000 USERS

Características generales / General features

	6800
Medidas / Dimensions	103 X 48 X 23 mm
Número de accesos / Door relays	1
Capacidad de usuarios / User capacity	Tarjeta / card (10.000)
Tipo de frecuencia / Frequency type	EM 125 Khz
Interface de comunicación / Communication interface	Wiegand 26
Modo de acceso / Access mode	Tarjeta - Llavero / Card - Clamshell tag
Voltaje / Voltage	12 VDC ±10%
Protección exterior / Outside protection	IP 68
Temperatura de trabajo / Operating temperature	-20 °C - 85 °C

Referencias / References

➤ **6800 KIT** Lector de tarjetas / Card reader
Fuente de alimentación / Power supply 220 ref 6902 V a/to 12 V DC
Cierre eléctrico / Electrical door opener. 1720 901 X / B
2 Tarjetas master (adición + eliminación) / 2 manager cards (add + delete)
5 Tarjeta de usuario / 5 User card
Mando a distancia para programar / Remote control for programming
Accesorio para reseteo / Reset pin

➤ **T 6800** Unidad de lectura / Reader unit

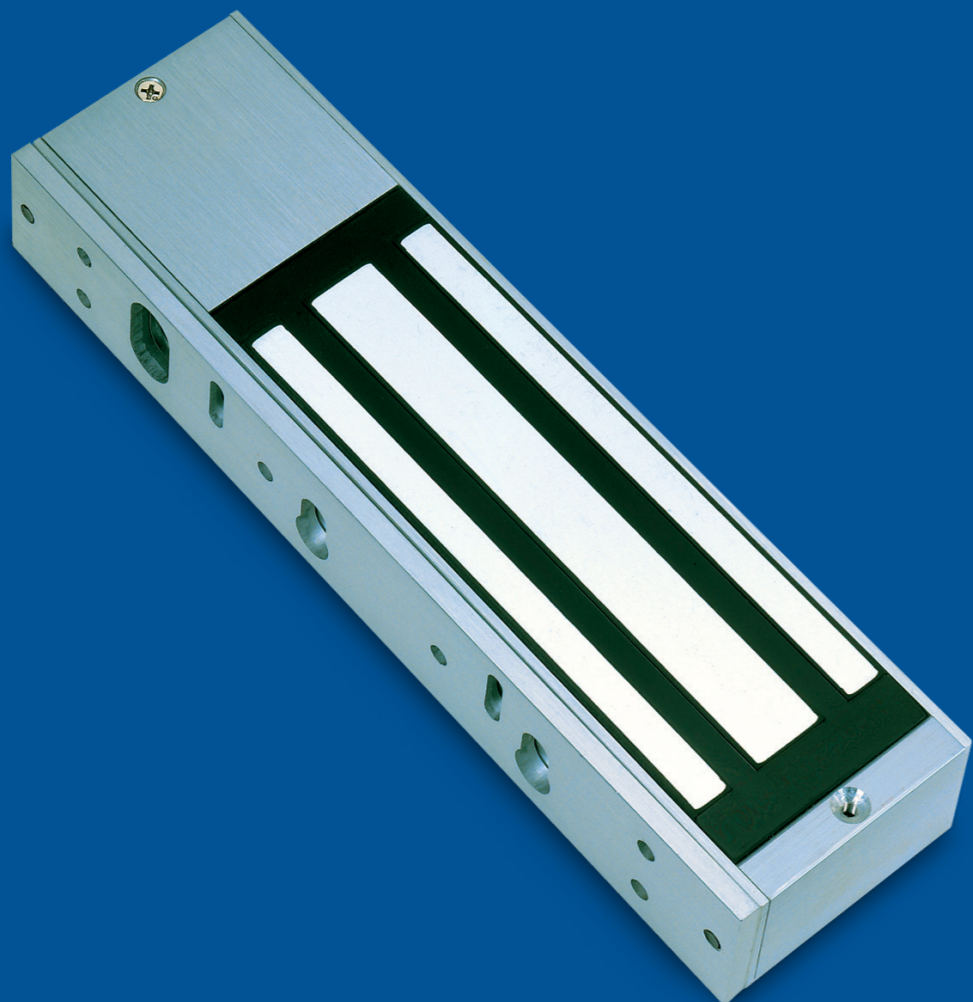
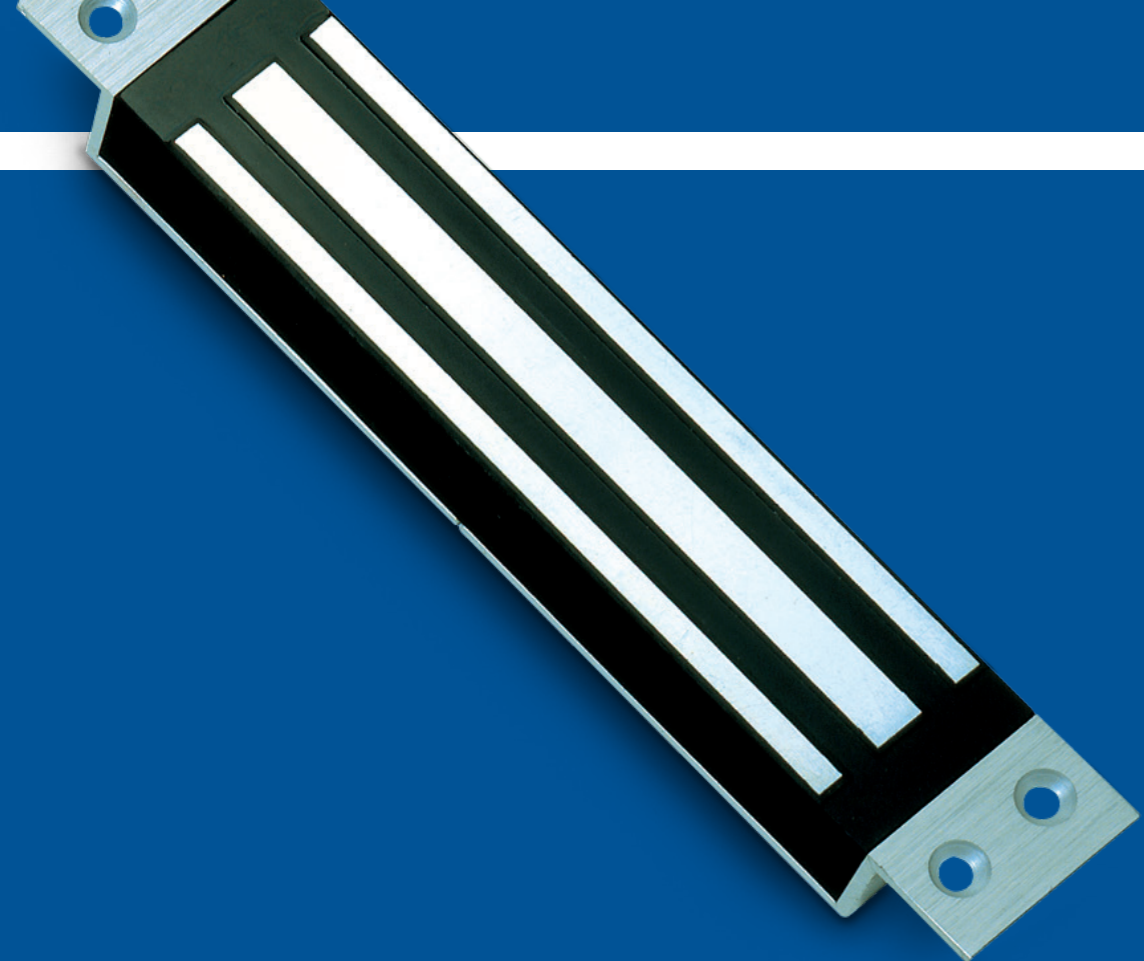

Electromagnéticos
Magnetic locks





RETENEDORES
DOOR HOLDERS



MINI MAGNET

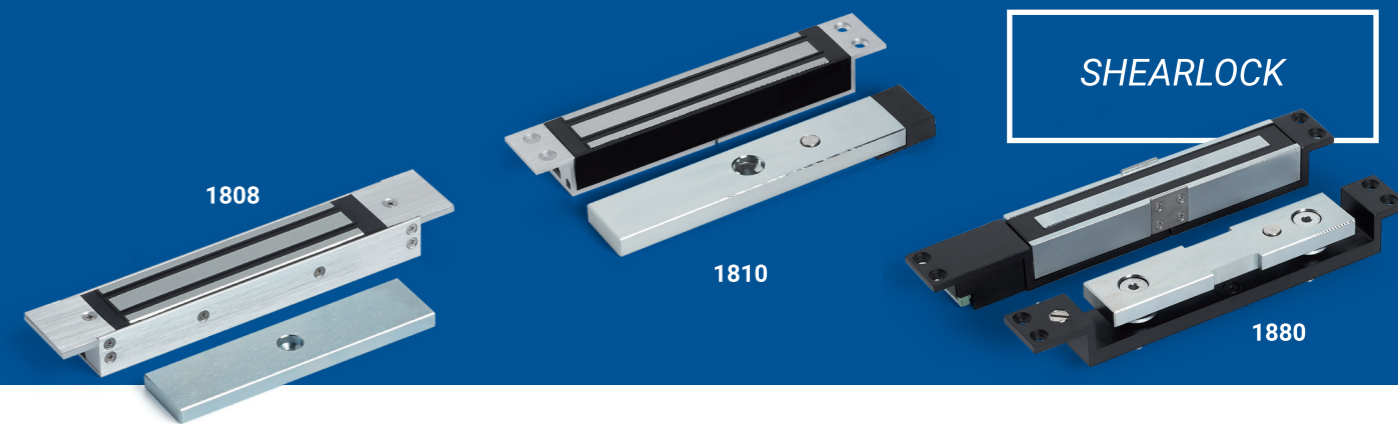

SHEARLOCK

Características técnicas / Technical specifications

	1802	1806	1807
Medidas / Dimensions	91 X 70 X 42,5 mm	112,5 mm	70 X 31 X 19 mm
Posición de instalación / Installation position	Pared / Wall	Suelo / Floor	Superficie / Surface
Contraplaca / Armature plate	∅ 54 mm	∅ 54 mm	62X 32 X 8,5 mm
Fuerza de retención / Holding force	500 N	500 N	350 N
Voltaje / Voltage	12 / 24 V DC	12 / 24 V DC	12 / 24 V DC
Consumo / Consumption 12 V DC	100 mA	100 mA	140 mA
Consumo / Consumption 24 V DC	50 mA	50 mA	70 mA
Fabricado en / Made in			Aluminio / Aluminium

Características técnicas / Technical specifications

	1808	1810	1880 Shearlock
Medidas / Dimensions	202 X 34,5 X 21,8 mm	228 X 38 X 27 mm	203 X 44 X 40 mm
Posición de instalación / Installation position	Embutir / Mortise		
Contraplaca / Armature plate	130 X 32 X 8 mm	205 X 38 X 12,5 mm	185 X 38 X 12,5 mm
Fuerza de retención / Holding force	1.300 N	3.000 N	3.000 N
Voltaje / Voltage	12 / 24 V DC	12 / 24 V DC	12 / 24 V DC
Consumo / Consumption 12 V DC	360 mA	500 mA	500 mA
Consumo / Consumption 24 V DC	180 mA	250 mA	250 mA
Fabricado en / Made in (cuerpo / body)	Aluminio / Aluminium	Aluminio / Aluminium	Inoxidable / Stainless
Sensor puerta / Door sensor	Si / Yes	Si / Yes	Si / Yes
Sensor puerta cerrada / Locked door sensor	Si / Yes	Si / Yes	NO
Temporizador / Timer	No	No	Si / Yes 0-30 s

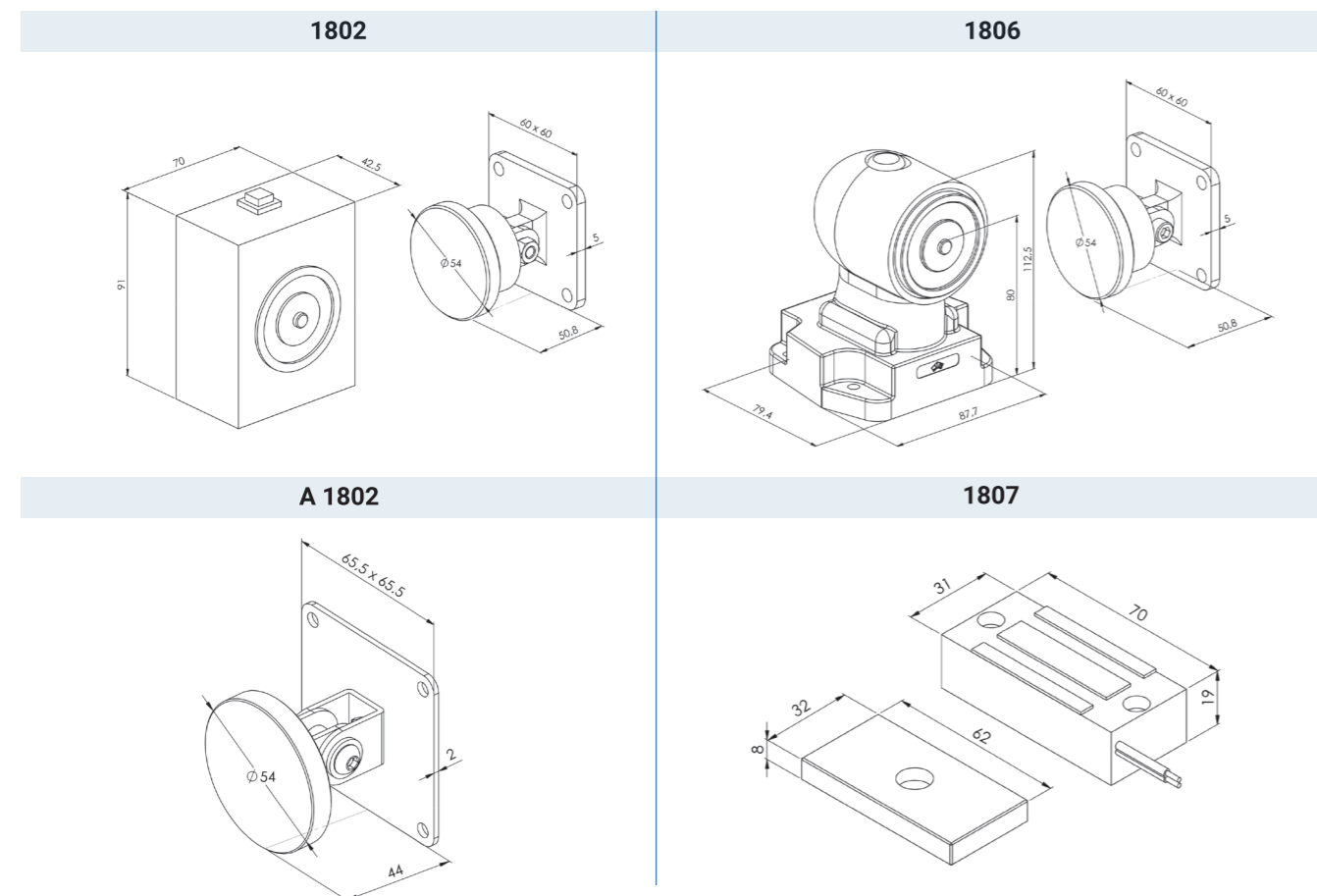

****Shearlock. Doble seguridad / Double security**

La fuerza magnética se ve reforzada por pernos. Esto previene cualquier deslizamiento lateral.
The magnetic force is reinforced by bolts. This prevents any slide movement.

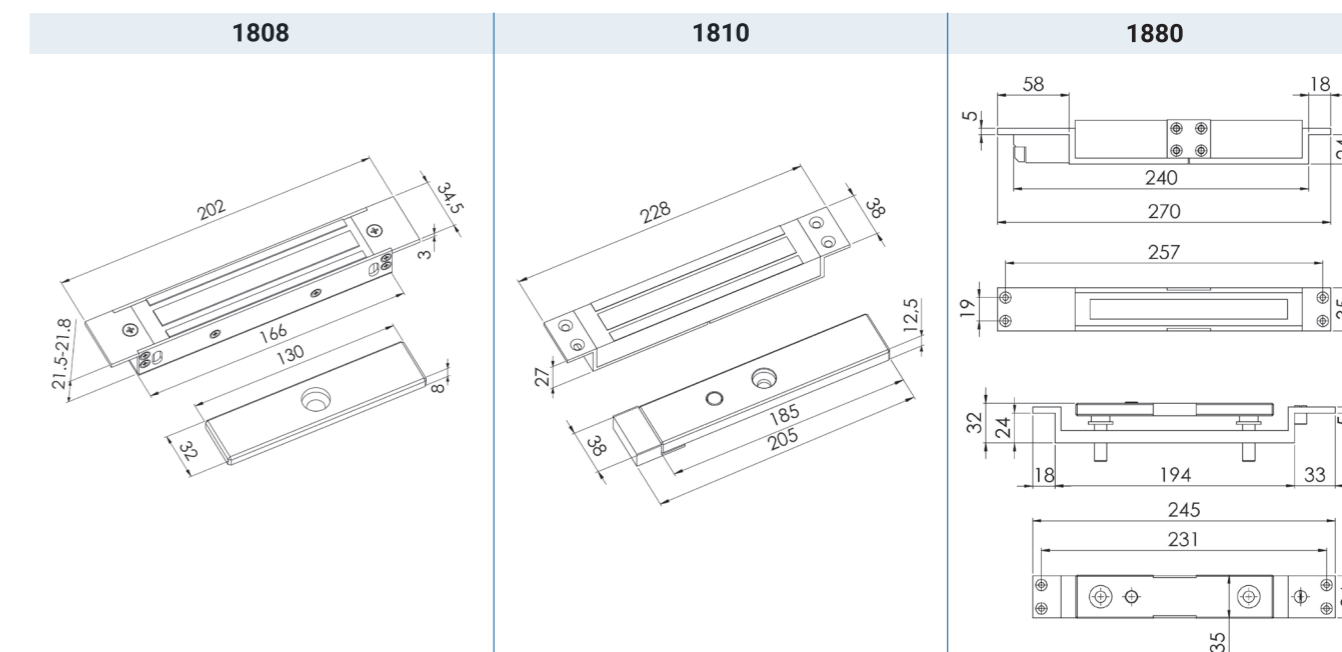

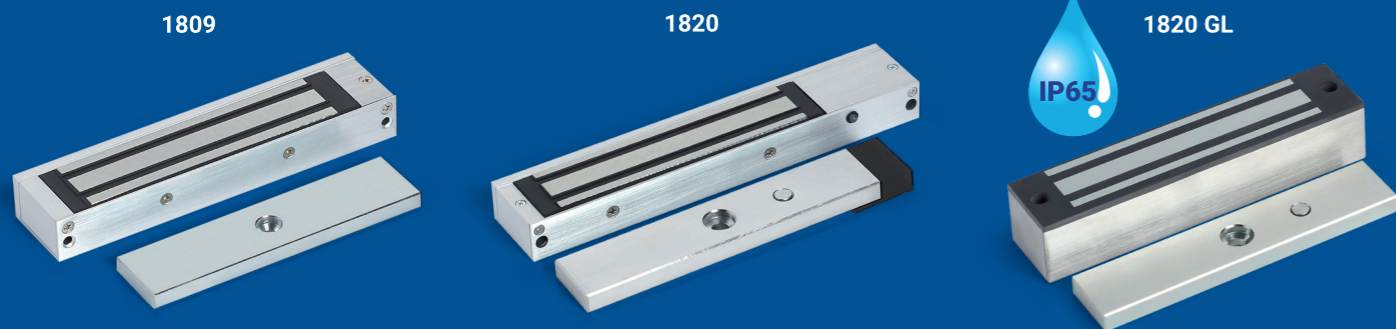

Características técnicas / Technical specifications

	1809	1820	1820 GL
Medidas / Dimensions	166 X 39 X 21,5 mm	250 X 47,5 X 25 mm	203 X 44 X 40 mm
Posición de instalación / Installation position	Superficie / Surface		
Contraplaca / Armature plate	130 X 21 X 8 mm	205 X 38 X 12,5 mm	185 X 38 X 12,5 mm
Fuerza de retención / Holding force	1.300 N	3.000 N	3.000 N
Voltaje / Voltage	12 / 24 V DC	12 / 24 V DC	12 / 24 V DC
Consumo / Consumption 12 V DC	360 mA	500 mA	500 mA
Consumo / Consumption 24 V DC	180 mA	250 mA	250 mA
Fabricado en / Made in	Aluminio / Aluminium	Aluminio / Aluminium	Inoxidable / Stainless steel
Sensor puerta / Door sensor	Si / Yes	Si / Yes	Si / Yes
Sensor puerta cerrada / Lock status sensor	NO	Si / Yes (LED)	No

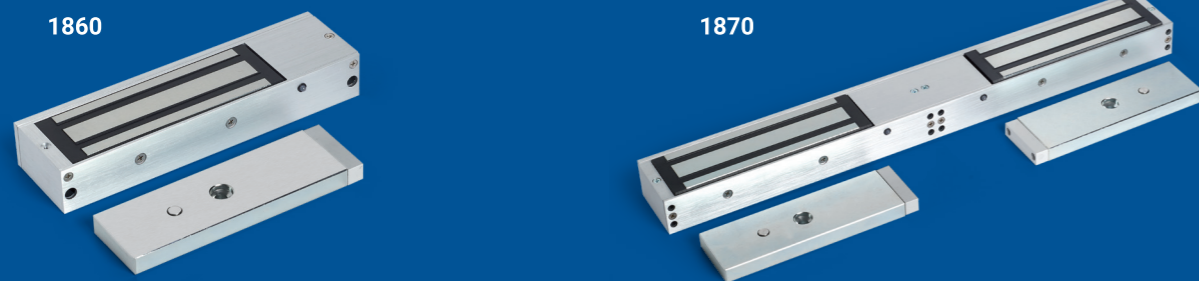

Características técnicas / Technical specifications

	1860	1870
Medidas / Dimensions	266 X 72,5 X 40 mm	532 X 73 X 40 mm
Posición de instalación / Installation position	Superficie / Surface	
Contraplaca / Armature plate	203 X 61 X 16 mm	203 X 61 X 16 mm (x2)
Fuerza de retención / Holding force	5.000 N	5.000 N (x2)
Voltaje / Voltage	12 / 24 V DC	12 / 24 V DC
Consumo / Consumption 12 V DC	500 mA	500 mA (x2)
Consumo / Consumption 24 V DC	250 mA	250 mA (x2)
Fabricado en / Made in	Aluminio / Aluminium	Aluminio / Aluminium
Sensor puerta / Door sensor	Si / Yes	Si / Yes
Sensor puerta cerrada / Lock status sensor	Si / Yes (LED)	Si / Yes (LED)

TIPOS DE INSTALACIÓN MAGNÉTICOS / MAGNETIC LOCKS INSTALLATION

APERTURA HACIA EL EXTERIOR / OUTWARD OPENING. ACCESORIO "L" BRACKET



APERTURA HACIA EL INTERIOR / INWARD OPENING. ACCESORIO "L Z" BRACKET

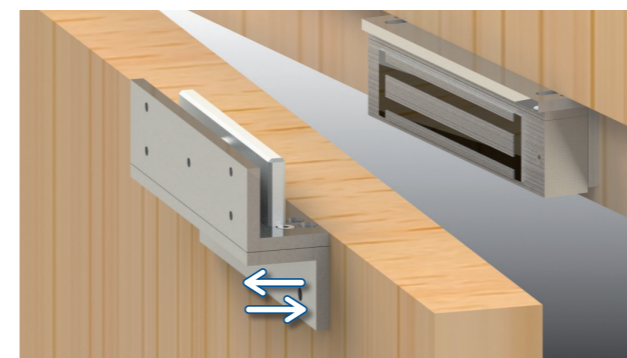

PUERTA VIDRIO / GLASS DOOR. ACCESORIO "U" BRACKET

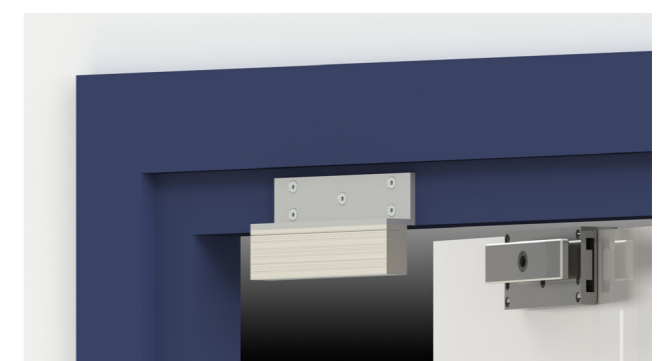

PUERTA CORREDERA / SLIDING DOOR (EMBUTIDO / MORTISE)

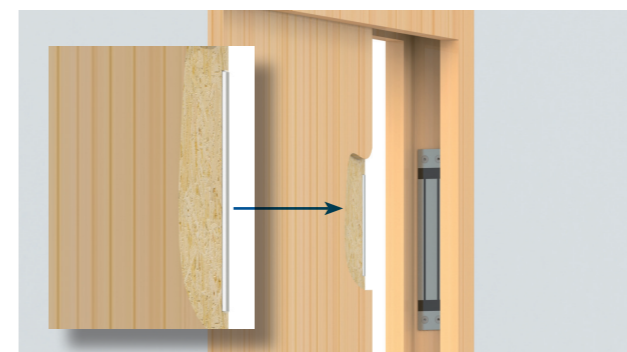

PUERTA CORTAFUEGO / FIRE DOOR

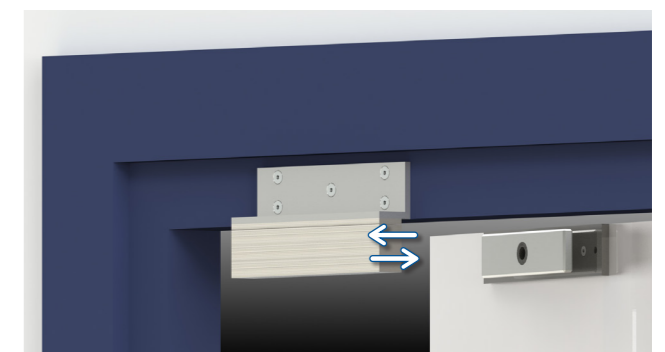

ACCESORIOS INSTALACIÓN INSTALLATION BRACKETS

SOPORTES PARA ELECTROMAGNÉTICOS BRACKETS FOR ELECTROMAGNETICS

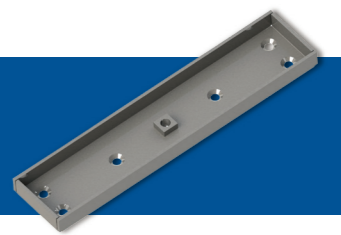
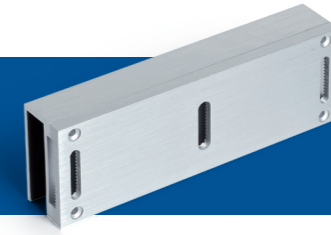
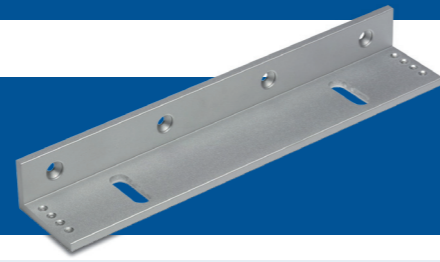

REF JIS
1809

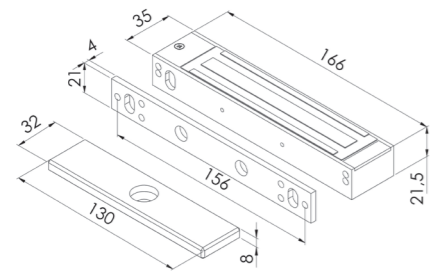

L
Apertura hacia fuera / Outward opening
1809 L

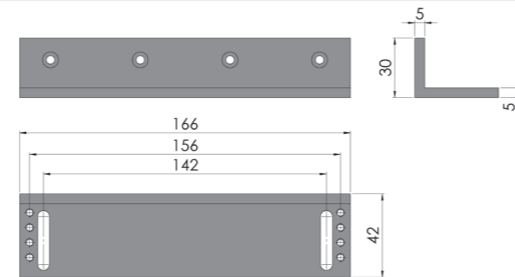

Z
Apertura hacia dentro / Inward opening
1809 Z

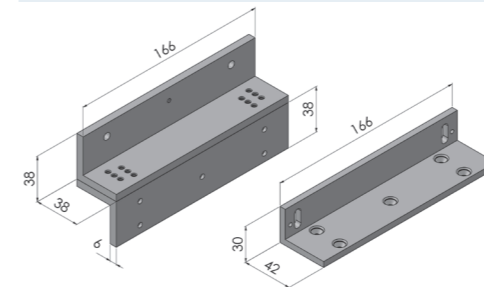

U
Puerta vidrio / Glass door
U 1809

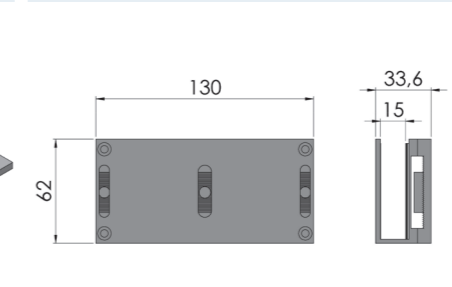

RF
Puerta cortafuego / Fireproof door
1820 RF

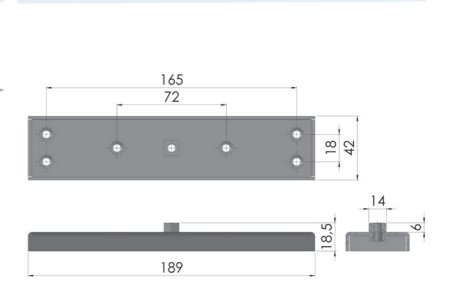

1820

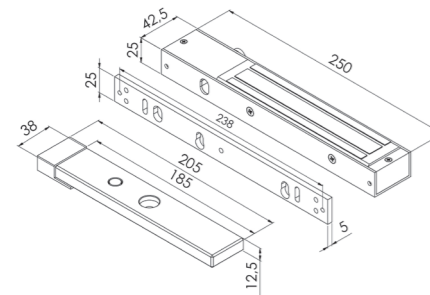

1820 L

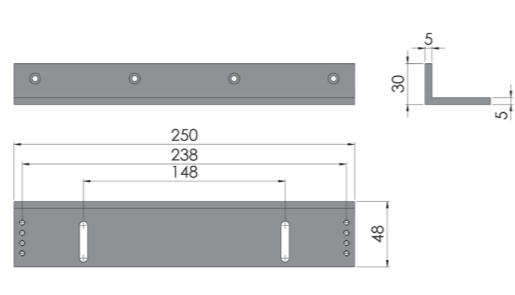

1820 Z

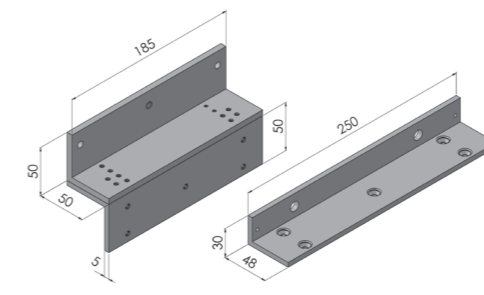

U 1820

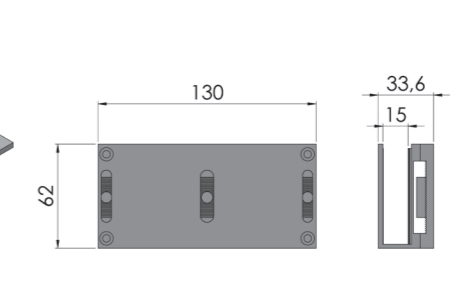

1820 GL

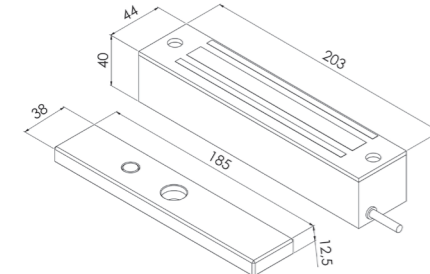

1820 GL

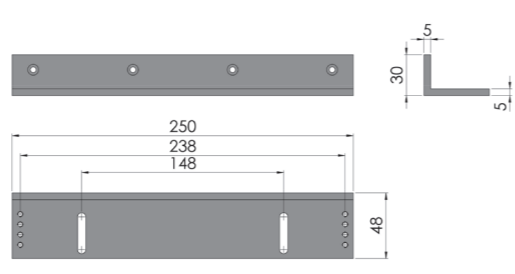

GL1820 Z

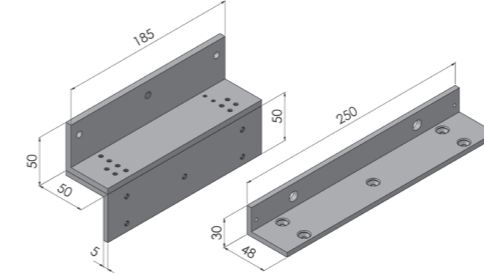

U 1820 GL

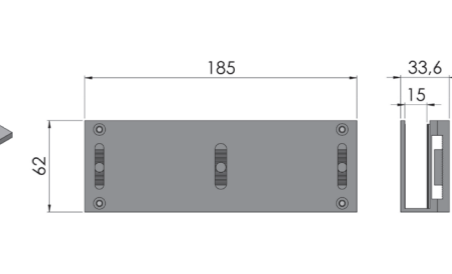

1860

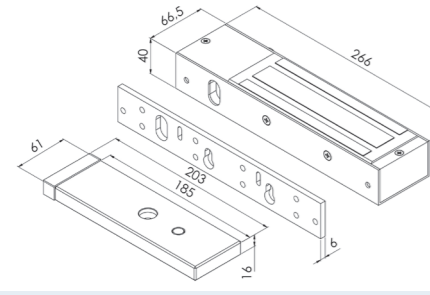

1860 L (x2)

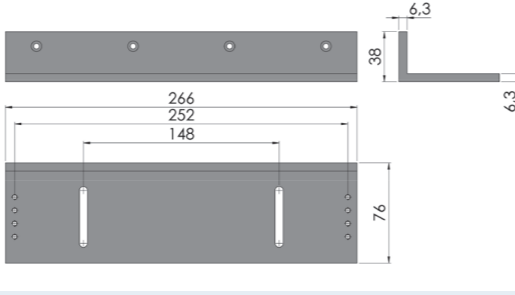

1860 Z (x2)

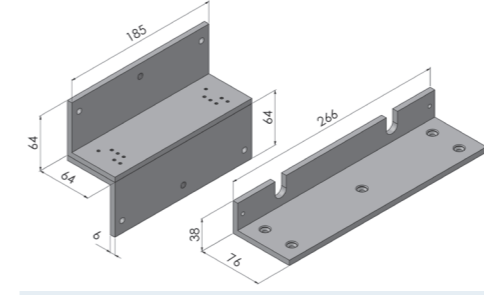

U 1860

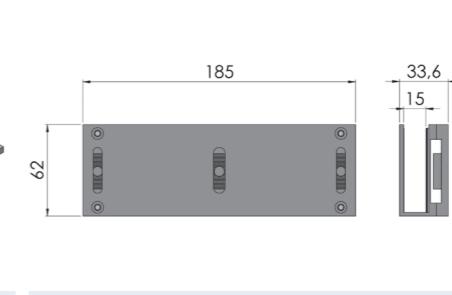

1870

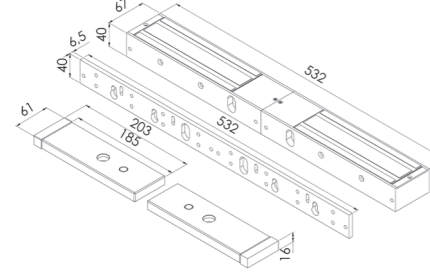

1870 L

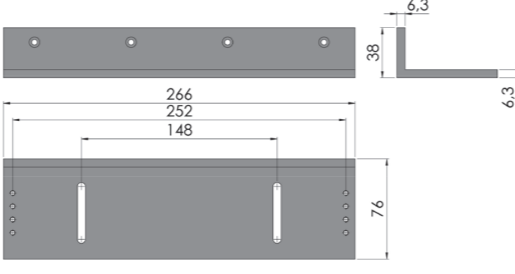

1870 Z

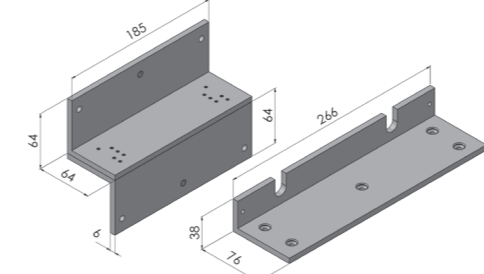

U 1820 /1860 (x2)

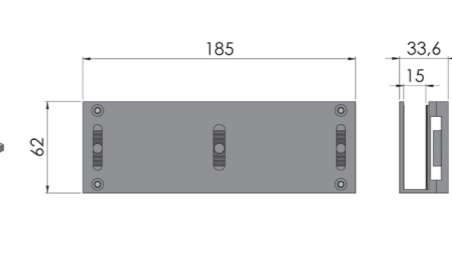

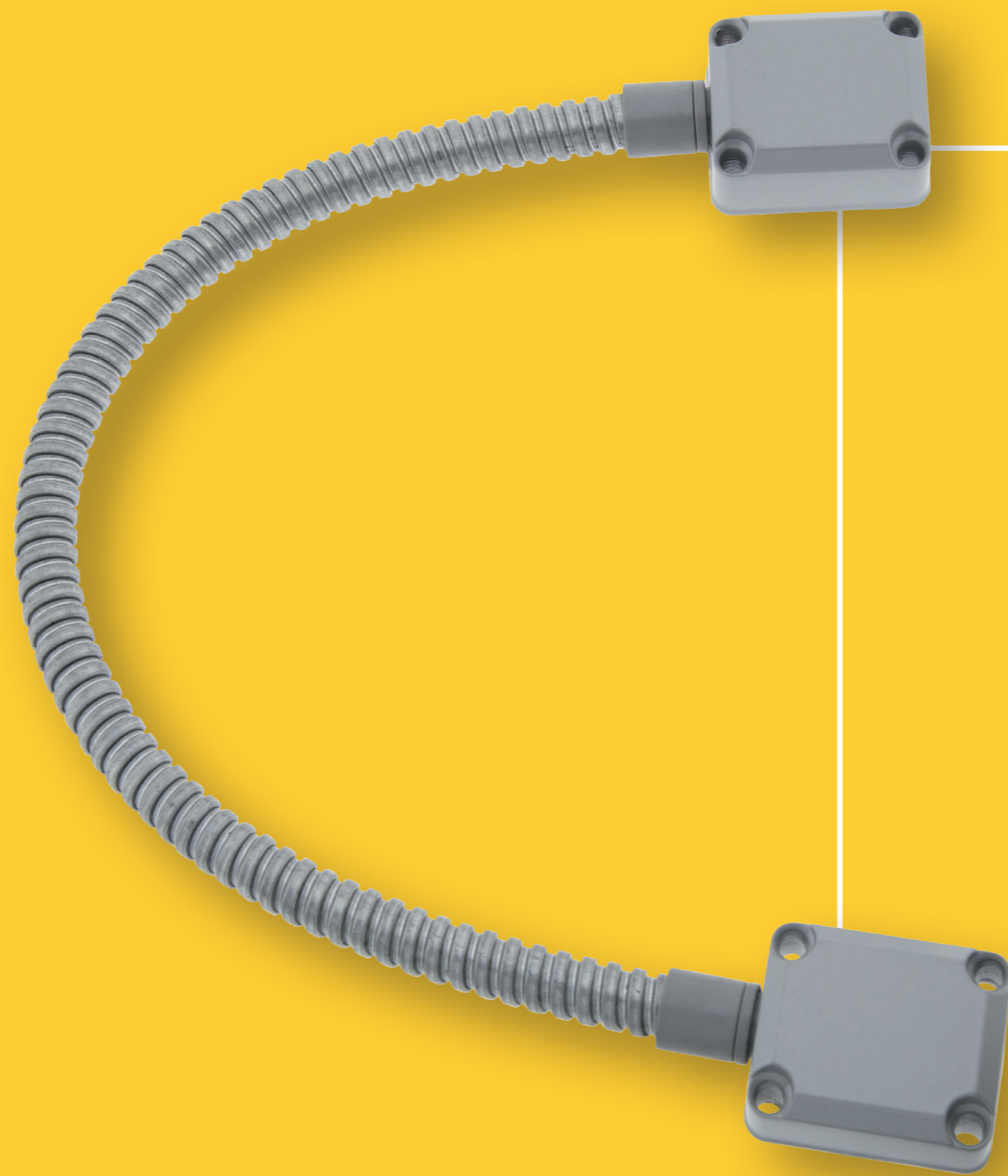

Accesorios
Accessories



ACCESORIOS / ACCESSORIES

TRANSFORMADORES Y FUENTES DE ALIMENTACIÓN / TRANSFORMERS AND POWER SUPPLIES

Transformador Transformer

6900



Transformador Transformer (DIN)

6901



Fuente Alimentación Power Supply (DIN)

6902



6903 - 6904



Características técnicas / Technical specifications

Referencia / Reference	Transformador / Transformer		Fuente alimentación / Power supply		
	6900	6901	6902	6903	6904
Medidas / Dimensions	60 X 50 X 42	53 X 83 X 60 mm	90 X 22,5 X 100	90 X 40 X 100 mm	90 X 40 X 100 mm
Voltaje entrada / Voltage input	220 - 230 V	220 - 230 V	220 - 230 V	220 - 230 V	220 - 230 V
Consumo máximo / Maximum consumption	1,5 A	1,6 A	1,7 A	5 A	2,5 A
Voltaje salida / Voltage output	12 V AC	12 V AC	12 V DC +/-10 %	12 V DC +/-20 %	24 V DC +/-20 %
Potencia / Power	15 W	14,5 W	60 W	60 W	60 W
Tipo Sujeción / Clamping type	Tornillo / Screw	DIN	DIN	DIN	DIN

*Productos indicados para todos los equipos JIS / Products suitable for all JIS equipments

PARA SISTEMAS DE APERTURA / FOR OPENING SYSTEMS: 6501 - 6502 - 6503- 6606 - 6700 - 6800

PR 6602



6



7



8



Para / for 6602

Características técnicas / Technical specifications

Referencia / Reference	PR 6602	6	7	8
Descripción / Description	Protector / Cover	Tarjeta usuario / User card	Pulsera usuario / User bracelet	Llavero usuario / User badge
Frecuencia / Frequency		EM 125 KHz	EM 125 KHz	EM 125 KHz
Medidas / Dimensions	140 x 100 x 90 mm			

PULSADORES / PUSH BUTTONS

Cerradura contacto Key release

6930



Pulsador Push button

6936



Pulsador proximidad No touch push button

6937



Pulsador emergencia Emergency push button

6940



Referencia / Reference	6930	6936	6937	6940
Medidas / Dimensions	95 X 95 x 45 mm	91 X 28 X 20 mm	86 X 86 X 11 mm	87,8 X 87,8 x 32 mm
Posición de instalación / Installation position	Superficie / Surface	Embutir / Mortise	Superficie / Surface	Superficie / Surface
Distancia activación / Activation distance			5-8 cm	
Voltaje / Voltage	125 / 230 V	Hasta / up to 36 V	12 V DC	12 / 24 V DC
Consumo máximo / Maximum consumption	16 A	3 A	3 A	3 A
Intensidad máxima / Max. intensity. Relé / Relay	250 VAC 10 A / 30 VDC 10 A		250 VAC 10 A / 30 VDC 10 A	250 VAC 10 A / 30 VDC 10 A
Tipo contacto / Contact types	NC / COM / NO	NO / COM	NC / COM / NO	NC / COM / NO

CONTROL REMOTO. EMISOR / RECEPTOR 6710 / REMOTE CONTROL. TRANSMITTER / RECEIVER 6710

Referencia / Reference	6710
Medidas / Dimensions	75 X 50 X 26 mm
Número de accesos / Door relay	NC / COM / NC
Intensidad máxima / Max. intensity. Relé / Relay	250 VAC 10 A / 30 VDC 10 A
Capacidad de usuarios / User capacity	16
Tipo de frecuencia / Frequency type	433 Mhz
Mode de acceso / Access mode	Control remoto / Remote control
Voltaje / Voltage	12 V DC
Protección exterior / Outside protection	NO
Temperatura de trabajo / Operating temperature	-20°C + 50°C
Alcance / Range	30 m
Tipos de códigos / Types code	Fijo / Fixed

*Ref E 6710. Mando a distancia / Remote control



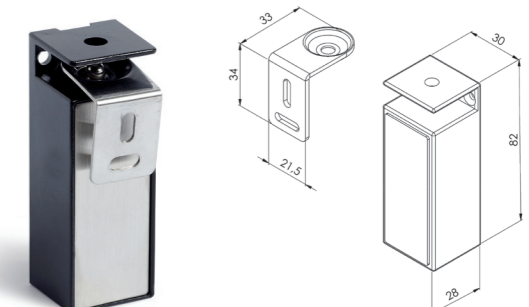

ELECTROPISTÓN PARA ARMARIO 1950 / CABINET DROPBOLT 1950

Referencia / Reference	1950
Medidas / Dimensions	82 X 30 X 28 mm
Posición de instalación / Installation position	Superficie / Surface
Voltaje / Voltage	12 / 24 V DC
Consumo / Consumption 12 V DC	300 mA
Consumo / Consumption 24 V DC	150 mA
Fabricado en / Made in (cuerpo / body)	Aluminio / Aluminium
Sensor puerta / Door sensor	NO

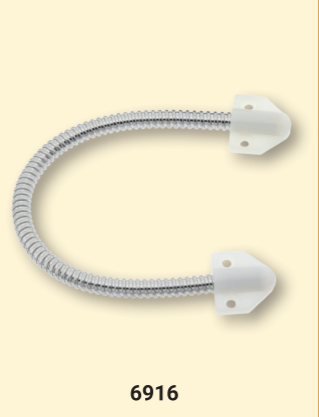
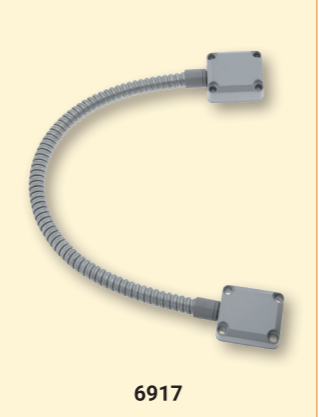

PASACABLES / DOOR LOOP

Características técnicas / Technical specifications

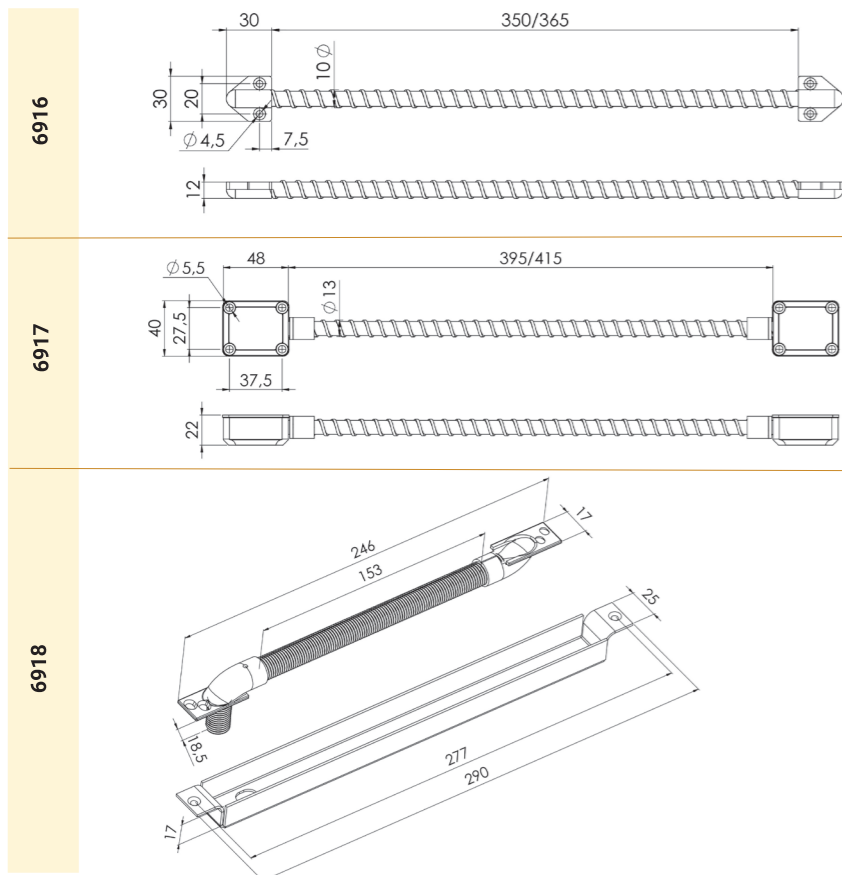

	De sobreponer Overlap instalation	De sobreponer Overlap instalation	Oculto Mortise instalation
			
	6916	6917	6918
Longitud flexo / Flex lenght	300 mm	360 mm	150 mm
Longitud total / Total lenght	345 mm	495 mm	290 mm
Acabados / Finishings	Cromo / Chrome / Plastic	Zamac / Cromo / Chrome	Cromo / Chrome
Aplicación / Application	Sobreponer / Rim	Sobreponer / Rim	Embutir / Mortise

Medidas / Dimensions

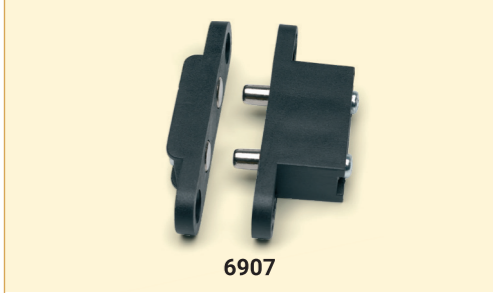

CONTACTOS ELÉCTRICOS / ELECTRIC CONTACTS

Características técnicas / Technical specifications

		
	6906	6907
Voltaje / Voltage	12 / 24 V	12 / 24 V
Consumo máximo / Max. consumption	2 A	2 A
		
	6908	6909
Voltaje / Voltage	12 / 24 V	12 / 24 V
Consumo máximo / Max. consumption	2 A	2 A

Medidas / Dimensions

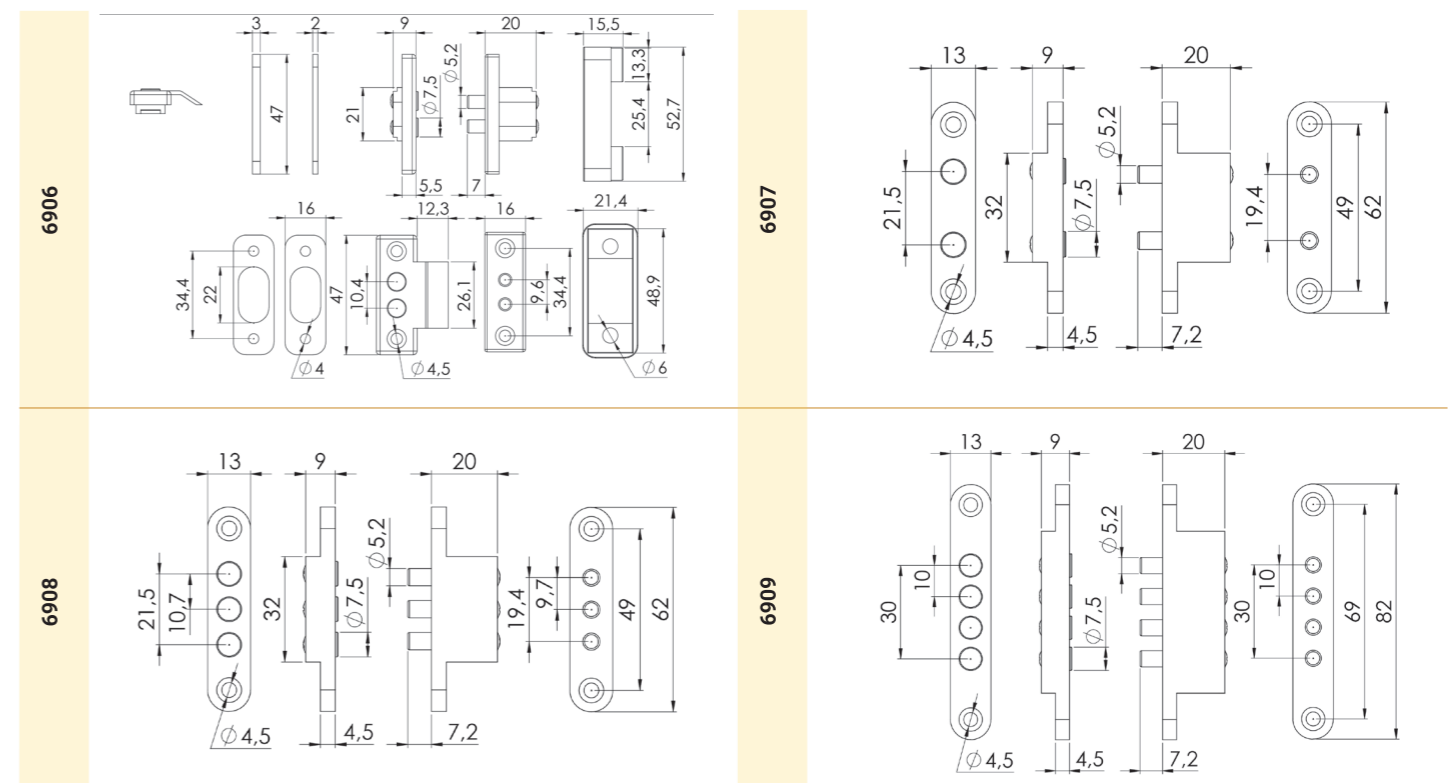

REFERENCIAS CIERRES ELÉCTRICOS REFERENCES ELECTRIC DOOR OPENERS

SERIE / SERIES			800	1700	1700	1400	1400 R	1400 RT	1480 RF	1480 RFT	1500	1580	1600	SOBREPONER			
					ANTI PANIC		RADIAL	RADIAL TOBOGÁN	RESIS. FUEGO FIRE RESISTANCE	RESIS. FUEGO FIRE RESISTANCE	ALTA SEGURIDAD HIGH SECURITY	RESIS. FUEGO FIRE RESISTANCE	ANTI PANIC	RIM			
														HOR.	VERT.		
Contacto normal Fail secure	Pestillo fijo Fixed latch	Estándar Standard		810		1770					1510	1580	1610	1015	1017		
			Palanca desbloqueo / Releasing lever	820		1772											
			Micro			1790						1560		1660			
		Memoria externa Pin External memory Pin		830												1035	1037
			Palanca desbloqueo / Releasing lever	840													
			Micro														
	Memoria interna Internal memory		833		1773						1553	1583	1633				
		Palanca desbloqueo / Releasing lever	843		1774												
		Micro									1563		1663				
		Estándar Standard		812	1710		1410	1410 R	1410 RT	1480 RF	1480 RFT						
			Palanca desbloqueo / Releasing lever	822	1720		1420	1420 R	1420 RT		1490 RFT						
			Micro		1760					1490 RF							
Memoria externa Pin External memory Pin		832	1730		1430	1430 R											
	Palanca desbloqueo / Releasing lever	842	1740		1440												
	Micro																
Memoria externa palanca Level external memory			1736		1436	1440 R											
	Palanca desbloqueo / Releasing lever		1746		1446												
	Micro																
Memoria interna Internal memory		834	1733		1433	1433 R	1433 RT										
	Palanca desbloqueo / Releasing lever	844	1743		1443	1443 R	1443 RT										
Contacto inverso Fail safe	Pestillo fijo Fixed latch				1771						1511	1581	1611	10151	10171		
		Micro			1791						1561		1661				
	Pestillo graduable Adjustable latch		811	1711		1411	1411 R	1411 RT	1481 RF	1481 RFT							
		Micro		1761					1491 RF	1491 RFT							

INSTALACIÓN / INSTALLATION

Comprobar que el voltaje y la intensidad del transformador o fuente alimentación, son los adecuados a los equipos.
Check that the voltage and intensity of the transformer or power supply are suitable for the equipments.

La incorrecta instalación o sobrecarga eléctrica anula la garantía.
Incorrect installation or overloading voids the warranty.

Garantía 3 años / 3 Year warranty.



NADAL BADAL, S.A.
c/ Electricitat, 12
Pol. Ind. Santa Rita
08755 CASTELLBISBAL
Barcelona - Spain

☎ Tel. +34 93 772 01 03

☎ Fax +34 93 772 13 63

✉ ventas@jis.es

✉ export@jis.es

✉ nadalbadal@jis.es

www.jis.es

Edición: 04/21

